

# TRAVEL AUTO BAG CO. INC.

**GARMENT DISPLAY, TRANSPORT & STORAGE**

**FOR SALESMAN, SHOWROOM, STUDIO & STORE**

**201.723.8941 - nuease@aol.com**

CLICK HEADING, BUTTON or IMAGE for DETAILS

## GARMENT BAG

- CANVAS GRIP-TITE BAG
- VINYL ZIPPERED COVER
- CLEAR GOWN BAG
- OPAQUE BRIDAL BAG

## ROLLING HARD CASE

- ROLLING TELESCOPE CASE
- SOFT-SIDE ROLLING CASE
- 6 DRAWER / JEWELRY CASE
- ROLLING DUFFLE / TOTE

## COLLAPSIBLE RACK

- FOLDING TRIPOD RACK
- COLLAPSIBLE ROLLING RACK
- RACK COVER / CARRIER
- RACK ACCESSORIES

## GARMENT HANGER

- SALESMAN'S WIRE HANGER
- PLASTIC GARMENT HANGER
- CONTOUR PLASTIC HANGER
- VELVET SLIMLINE HANGER

## EASY ORDER - 1,2,3

HOW TO ORDER

PRICE LIST

ORDER FORM

E-MAIL ORDER

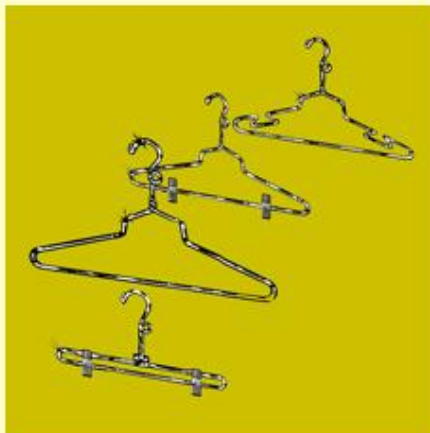

## WARDROBE SUPPLY

- CLEAR DRAWSTRING BAG
- WARDROBE STEAMER
- WARDROBE BAG
- WARDROBE RACK

## SHOWROOM RACK

- SHOWROOM RACK / CHROME
- SHOWROOM RACK / BLACK
- GRID DISPLAY RACK / CHR
- CLASSIC PIPE RACK / GRY-WHT

## STORE FIXTURE

- GRID WALL / CHR-BLK
- LADDER WALL SYSTEM / BLK
- STORE COSTUMER / CHR-BLK
- EURO WALL SYSTEM / WHT

## MANNEQUIN

- FLEXIBLE MANNEQUIN
- FLEXIBLE JERSEY FORM
- CLASSIC JERSEY FORM
- PLUS-SIZE MANNEQUIN

## INDEX PAGE

CATALOG INDEX

DOWNLOAD PDF CATALOG

DOWNLOAD PRICES

CONTACT US



**ALWAYS IN STOCK!**



**SAME DAY DELIVERY!**



NYC, BROOKLYN, NJ

**GARMENT CENTER ANYWHERE  
USE ONLINE CATALOG**

GARMENT SALES EQUIPMENT  
STORE DISPLAY FIXTURES  
MOVIE WARDROBE SUPPLY

Hard fiber cases, travel bags on wheels, rolling sample cases, folding tripod rack, canvas garment bag, collapsible rolling rack, suit covers, clear gown bags, wardrobe supply, rolling showroom racks, steamers, plastic hanger, chrome wire hangers, garment sample case, salesman travel bag, bendable jersey form, store display fixtures, flexible mannequins forms and movie wardrobe supplies.

*Nu-Ease*  
SINCE 1933

**WARDROBE SUPPLY**



**ONLINE CATALOG**

PG# WEB CATALOG INDEX - PAGE LINKS CLICK PAGE# OR TITLE

1	Garment bag  salesman griptite garment bag, rack cover
2	Travel bags  vinyl suit cover, opaque dress carrier, gown bag
3	Sustainable garment covers  non-woven bag, shopping bags
4	Wardrobe bag  gown bags clear, bridal garment bag opaque
5	Garment steamer  professional clothes steamers
6	Salesman luggage  rolling duffel, drop-bottom tote
7	Rolling soft-side case  travel bag with wheels
8	Hard case with wheels  rolling hard fiber cases
9	Hard sided cases  rolling prop case, jewelry wheeler, super cases
10	Salesman tripod rack  folding tripod racks, trade show display
11	Salesman rolling racks  collapsible garment rack
12	Trade show light  quartz-halogen flood, stand, clamp, bulb
13	Chrome salesman hangers  chrome wire hanger for travel bag
14	Flocked hangers  velvet slimline hanger, hanging torso form
15	Plastic garment hanger  dress hangers, skirt hanger
16	Wood hanger  natural wood jacket hanger, wooden skirt hangers
17	Plastic jacket hangers  plastic coat hanger, shoulder shaped
18	Showroom garment racks  garment showroom display rack
19	Garment showroom rack   rolling garment racks
20	Black display fixtures  black merchandiser, rolling display
21	Wardrobe racks  rolling stockroom rack
22	Budget fixture display  costumers, 2-way & 4-way racks
23	Store merchandisers  Bauhaus garment racks
24	Retail garment fixtures  cross merchandisers
25	Wall display rack  Alta wall fixture system
26	Grid wall panels  grid display system, gridwall accessories
27	Gridwall brackets  grid waterfalls, shelves, hangrails
28	Ladder wall units  merhandisers, shelving, hanging units
29	Rolling ladder wall  wall units on wheels, ladder accessories
30	Euro display fixture system  hanging rack, costumer, wall unit
31	Euro fixture accessories  chrome & white face-outs
32	System mannequins  modular torso manikin
33	System mannequin series  3/4 torso forms
34	Flexible mannequins  poseable manikins, bendable child form
35	Jersey forms  knit covered manikin, fabric wrapped mannequin
36	Flexible jersey manikins  moveable arms & legs, jersey covered
37	Plastic mannequins  sexy display manikin, plus size forms
38	New items  glossy black mannequin, athletic manikin series
39	Clearance items  wood hanger, Brazilian mannequins
40	Wardrobe supplies  costume bags, hangers, storage racks
41	"Just for fun"  original fiction, audio stories, quotations
42	"Flick Funnies"  captioned movie stills, vintage art

EASY ORDERING 1,2,3

Download PRICE LIST.  
CALL, E-MAIL or FAX your order in.  
CONFIRMATION E-mailed, quickly!  
SAME DAY VAN SERVICE available!

HOW TO ORDER

PRICE LIST

ORDER FORM

E-MAIL ORDER

SEND ORDER FORM AS EMAIL ATTACHMENT  
WILL PRINT & DELETE IMMEDIATELY  
SAVED AS A SECURE OFF-LINE FILE!

FOR HELP:  
EMAIL: [nuease@aol.com](mailto:nuease@aol.com)  
OR CALL: 201.723.8941  
SALES WILL CALL [within 15 min]  
TO ANSWER YOUR QUESTIONS.  
WE'LL GLADLY TAKE YOUR ORDER.

REQUEST A QUOTATION

Submit BILLING / SHIPPING, TEL#, CELL#, E-MAIL.  
We'll E-mail YOUR QUOTATION.

E-MAIL, CALL OR FAX your CC#.  
We'll expedite your ORDER.  
CONFIRMATION E-mailed within 2 hours.  
Most orders SHIP SAME DAY or NEXT!

CONTACT US

CONTACT INFORMATION

Travel Auto Bag Co., Inc.  
PO Box#5568, Englewood, NJ 07631  
TEL: 201-723-8941 DIRECT  
FAX: 201-837-9427  
EMAIL: [info@travelautobag.com](mailto:info@travelautobag.com)

CONTACT US

GARMENT SALES SUPPLY  
STORE DISPLAY FIXTURES  
MOVIE & TV WARDROBE SUPPLY

Hard fiber cases, travel bags on wheels, rolling sample cases, folding tripod rack, canvas garment bag, collapsible rolling rack, suit covers, clear gown bags, wardrobe supply, rolling showroom racks, steamers, plastic hanger, chrome wire hangers, garment sample case, salesman travel bag, bendable jersey form, store display fixtures, flexible mannequins forms and movie wardrobe supplies.

DOWNLOAD PDF CATALOG

DOWNLOAD PRICES



SAME DAY DELIVERY!



NYC, BROOKLYN, NJ



NAVIGATE

NEXT>

<BACK

HOME

TRAVEL AUTO BAG CO., INC.

201.723.8941

THE MOST EFFECTIVE WAY TO TRANSPORT ALL TYPES OF GARMENTS. MADE OF DURABLE CANVAS OR NYLON, THE "GRIP TITE" HOLDS UP TO [30] GARMENTS SECURELY IN A PATENTED 15" RUBBER LINED CLAMP WHICH PREVENTS HANGERS FROM SLIPPING BACK INTO THE BAG. USED WITH SALESMEN'S LOOP CHROME WIRE HANGERS, GRIP-TITES CAN BE TRUSTED TO SAFELY CONVEY YOUR GOODS BY CAR, PLANE OR TRUCK.

## STILL MADE IN THE USA!

CANVAS DIMENSIONS NYLON BEST USED FOR  
 #GT38 38 X 24 X 15" CHILDRENSWEAR, SHIRTS, BLOUSES  
 #GT42 42 X 24 X 15" #GT42N JACKETS, SWEATERS, SWIMWEAR  
 #GT48 48 X 24 X 15" #GT48N SHORT DRESSES, PANTS, COATS  
 #GT57 57 X 24 X 15" #GT57N DRESSES, LINGERIE, COATS, ROBES  
 #GT66 66 X 24 X 15" #GT66N FLOOR LENGTH DRESSES, GOWNS  
 #GT72 72 X 24 X 15" #GT72N BRIDAL GOWNS ONLY  
 COLOR: NAVY BLUE

CANVAS: HEAVY-DUTY 14 OZ. COTTON DUCK IN A WATER REPELLANT FINISH. FULLY TESTED NOT TO BLEED. STRONGEST GOODS THAT ARE THE MOST TEAR OR SLASH RESISTANT. RECOMMENDED.

NYLON: 200 DENIER OXFORD NYLON WITH A WATERPROOF FINISH. LIGHTWEIGHT, ATTRACTIVE, STAYS CLEAN, BUT NOT AS STRONG AS CANVAS.



THE ORIGINAL GRIP-TITE CLAMP TOP!

STILL MADE IN THE USA!

GT38 - GT72

## RELATED ITEMS



VINYL SUIT COVER



NON-WOVEN BAGS



OPAQUE BRIDAL COVERS



CLEAR GOWN BAGS



CLEAR DRAWSTRING



WARDROBE SUPPLY

## RACK COVERS / RACK CARRIERS

## BALLISTIC NYLON

### RACK COVER WATERPROOF / LOCKABLE



RB50

ZRC4L



### RACK CARRIER 1000 DENIER CORDURA NYLON!

#RB50: CARRY CASE[FOR FOLDING ROLLING RACKS]

SUPER-STRONG, 1000 DENIER CORDURA NYLON, FOAM PADDED AND TRIPLE REINFORCED. HEAVY WEB HANDLES, ZIPPERED ON THREE SIDES, HOLDS "WHEELABOUT" AND "BIG WHEELER".

HOLDS 1-2 RACKS: #SWF and #BW5 RACKS

#ZRC4L:[50L X 24W X 60"H] RACK COVER

LOCKABLE, ZIPPERED RACK COVER PROVIDES SECURITY AT TRADESHOWS OR TRANSPORTING GARMENTS BETWEEN STORES. THE #ZRC4L FITS THE #SWF-ADJ AND #BW5 RACKS. MADE OF HEAVY WATERPROOF NYLON WITH A DURABLE ZIPPER CLOSURE ON BOTTOM.

nuease@aol.com | TEL: 201.723.8941 | FAX: 1-201-837-9427

### NAVIGATE

NEXT >

< BACK

INDEX

### ORDERING 1,2,3

HOW TO ORDER

PRICE LIST

ORDER FORM

E-MAIL ORDER

### COMPLETE INDEX

CATALOG INDEX

DOWNLOAD PDF CATALOG

CONTACT US

SEND ORDER FORM AS EMAIL ATTACHMENT  
 WILL PRINT & DELETE IMMEDIATELY



IMPRINTED WITH YOUR LOGO, VINYL SUIT COVERS ARE THE BEST ADVERTISING VALUE. THEIR SMART LOOKS ENHANCE YOUR COMPANY'S IMAGE AND PRESTIGE. OUR BAGS ARE MADE OF 3 MIL. VIRGIN PVC VINYL THAT IS SUPPLE AND CRACK RESISTANT. BEWARE RECYCLED VINYL OR PVE BAGS SOLD ON THE NET THAT PALE IN COMPARISON. IT'S YOUR IMAGE AT STAKE!



CANVAS GRIP TITE



NON-WOVEN BAGS



GUSSETED BRIDAL BAG



OPAQUE BRIDAL COVERS



CLEAR GOWN BAGS



WARDROBE SUPPLY

**BRING A HIGH FASHION LOOK TO YOUR BUSINESS WITH OUR HANDSOME, HIGH QUALITY, 3 GUAGE, ZIPPERED SUIT & COAT COVERS.**

ANY COLOR BAG, ANY COLOR IMPRINT, YOUR LOGO

**BLANK BAGS, IN STOCK, IMMEDIATE DELIVERY!**

**NON-IMPRINTED**

- #40 BLACK 40 X 24"
- #54 BLACK 54 X 24"
- #66 BLACK 66 X 24"
- BLANK BAGS = BLACK
- 100 PER BOX

IMPRINTED SPECS >>>  
SIZES & COLORS BELOW  
ALSO AVAILABLE

ARTWORK: E-MAIL A .PDF FILE OF YOUR LOGO IN BLACK & WHITE. CAN BE PRINTED IN ANY COLOR  
PLATE: ONE-TIME PLATE CHARGE FOR NEW LOGOS. PLATES ARE FILED FOR RE-USE ON FUTURE ORDERS

PRINTING: BAGS ARE IMPRINTED BY A HOT-STAMPING PROCESS THAT EMBOSES THE VINYL WITH A COLORED FOIL. IMPRINT CAN ONLY BE MADE IN A 6 X 6" AREA BELOW THE OVAL WINDOW. ONE COLOR ONLY!

COLORS: BAGS MAY BE HOT STAMPED WITH ANY OF THE FOLLOWING COLOR FOILS: BLACK, BEIGE, YELLOW, GREY, GOLD, SILVER, WHITE, ORANGE, RED, HOT PINK, LIGHT PINK, DARK GREEN, LIGHT GREEN, DARK BROWN, LGHT BROWN, NAVY BLUE, LIGHT BLUE, ROYAL BLUE, BURGUNDY.

**SIZE: 40 X 24**

- #40B/B
- #40B/G
- #40R/B
- #40G/B
- #40/W
- #40/N
- #40/M
- #40/S
- #40/T
- #40/V
- #40/H
- #40/K
- #40/NY
- #40/C

**SIZE: 54 X 24**

- #54B/B
- #54B/G
- #54R/B
- #54G/B
- #54/W
- #54/N
- #54/M
- #54/S
- #54/T
- #54/V
- #54/H
- #54/K
- #54/NY
- #54/C

**SIZE: 54 X 24**

- #66B/B

**BAG COLOR / TRIM COLOR**

- BLACK / BLACK
- BLACK / GOLD
- RED / RED
- GREY / GREY
- WHITE / WHITE
- BROWN / BROWN
- MAROON / MAROON
- SILVER / SILVER
- BEIGE / BEIGE
- MEDIUM BLUE / MEDIUM BLUE
- GREEN / GREEN
- BURGUNDY / BURGUNDY
- NAVY BLUE / NAVY BLUE
- CLEAR / CLEAR

nuease@aol.com | TEL: 201.723.8941 | FAX: 1-201-837-9427

NAVIGATE

- NEXT>
- <BACK
- INDEX

ORDERING 1,2,3

- HOW TO ORDER
- PRICE LIST
- ORDER FORM
- E-MAIL ORDER

COMPLETE INDEX

- CATALOG INDEX
- DOWNLOAD PDF CATALOG
- CONTACT US

SEND ORDER FORM AS EMAIL ATTACHMENT

POLY BAGS THAT ARE PERFORATED FOR A CANVAS LOOK. MADE OF 75 GRAM PP GUAGE THAT MAKES FOR A DURABLE, BREATHABLE AND SUSTAINABLE GARMENT BAG. STRONG ENOUGH TO BE A REUSABLE UPSCALE ALTERNATIVE TO OUR REGULAR PVC BAGS, COSTING JUST A LITTLE BIT MORE. A REUSABLE BAG SUITABLE FOR SENDING SAMPLES TO BUYERS, PHOTO STUDIOS AND PR OFFICES. GREAT FOR MOVIE WARDROBE OR THEATRICAL COSTUME STORAGE.



**BRIDAL BAG**  
72 X 24 X 3"

**SUIT - DRESS**  
40 & 54"

NW40BKB  
NW54BKB

NW723BKB  
NW23WKB

CLEAR POCKET  
ID WINDOW  
75 GRAM NON-WOVEN

BLACK  
WHITE



CANVAS GRIP-TITE BAG



VINYL SUIT COVER



OPAQUE BRIDAL COVERS



CLEAR GOWN BAGS



CLEAR DRAWSTRING

NON-WOVEN GARMENT BAGS  
#NW40BKB: [24 X 40"] BLACK  
#NW54BKB: [24 X 54"] BLACK  
#NW723BKB: [24 X 72 X 3"] BLACK  
#NW23WKB: [24 X 72 X 3"] WHITE  
BOX = 50 PCS / 100 PC MIN

**SUSTAINABLE - BREATHABLE - DURABLE  
UNIQUE BREATHABLE PERFORATED POLY  
LOOKS AND BREATHES LIKE CANVAS!**

LOOP HANDLE SHOPPING BAGS

PLASTIC - PAPER

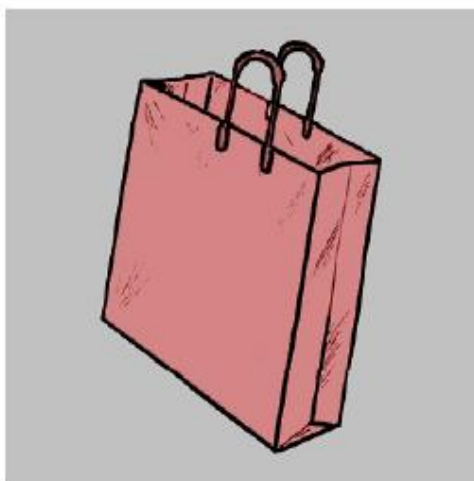

#LH3:  
LOOP HANDLE BAGS [3 MIL] POLY  
EXTRA LARGE 21 X 16 X 6" SHOPPING  
BAGS WITH GUSSET AND A HEAVY  
PLASTIC LOOP. BLACK ONLY  
BOX = 500 PCS [ONLY]

#PB16619:  
ROPE HANDLE PAPER BAGS  
EXTRA LARGE 16 X 6 X 19" KRAFT  
PAPER SHOPPING BAGS IN NATURAL  
FINISH. LOOP STYLE ROPE HANDLE.  
BOX = 200 PCS [ONLY]



nuease@aol.com | TEL: 201.723.8941 | FAX: 1-201-837-9427

NAVIGATE

- [NEXT >](#)
- [< BACK](#)
- [INDEX](#)

ORDERING 1,2,3

- [HOW TO ORDER](#)
- [PRICE LIST](#)
- [ORDER FORM](#)
- [E-MAIL ORDER](#)

COMPLETE INDEX

- [CATALOG INDEX](#)
- [DOWNLOAD PDF CATALOG](#)
- [CONTACT US](#)

SEND ORDER FORM AS EMAIL ATTACHMENT

**WARDROBE SUPPLY**

EVERYTHING FOR WARDROBE  
ON LOCATION  
IN STUDIO  
NYC NJ DAILY VANS MANHATTAN SINCE 1933

WARDROBE SUPPLY

YOUR LOGO IMPRINTED IN GOLD OR BLACK, FREE WITH ANY ORDER OF 100 OR MORE. HAVE YOUR LOGO REPRODUCED BY SENDING A B/W GLOSSY, LETTERHEAD, HANGTAG, CATALOG SHEET OR E-MAIL A DIGITAL IMAGE AND WE'LL MAKE A DIE. ONE-TIME PLATE CHARGE. OTHERWISE, WE CAN SET BLOCK LETTERING OF YOUR NAME.



**FULL LENGTH  
10" GUSSET**

**3 GAUGE  
OPAQUE  
WHITE**

**WGS72**

#WGS72: BRIDAL BAG: WHITE WITH FULL 10" GUSSET HAS A CLEAR VINYL WORK TICKET POUCH AND A REINFORCED HANGER OPENING. COLOR: WHITE SIZE: 24 X 10 X 72" FULL 10" GUSSET WITH ID POUCH IMPRINTABLE: 100 MINIMUM



**W72/P**

**W72/W**

**W72/B**

#W72: [WHITE] #W72/P: [PINK] #W72/B: [BLACK] 3 GAUGE OPAQUE VINYL. CLEAR TICKET POCKET. BELL SHAPED BOTTOM AND 72" LENGTH COLORS: WHITE/ WHITE TRIM, PINK/ PINK TRIM, BLACK/ BLACK SIZE: 24-36" X 72" IMPRINT: 100



**CANVAS GRIP-TITE BAG**



**VINYL SUIT COVER**



**NON-WOVEN BAGS**



**PRO GARMENT STEAMER**



**ROLLING DUFFLES**



**WARDROBE SUPPLY**

**DRAWSTRING ACCESSORY BAG**

**CRYSTAL CLEAR**



**BAG HOLDS  
ACCESSORIES**

**CLEAR BAG  
DRAWSTRING  
22 X 18"**

**DS1822**

#DS1822: 2 MIL CLEAR POLY/ 18 X 22" [500 BAGS/ BOX] DRAWSTRING POLY BAGS FOR THE FILM, FASHION AND PUBLISHING INDUSTRIES. TOUGH 2 MIL. PLASTIC WITH DURABLE COTTON DRAWCORD. CRYSTAL CLEAR.



**CLEAR  
WARDROBE  
BAGS**

**4 GAUGE  
CRYSTAL  
CLEAR**

**BB54  
BB66  
BB72**

CRYSTAL CLEAR #BB54:24 X 54" #BB66=24 X 66" #BB72=24 X 72" COMPLETE PROTECTION FOR BRIDALS AND GOWNS. HEAVY 4 GAUGE VINYLITE. FULL LENGTH ZIPPER. 10" GUSSET AT BOTTOM.

[nuease@aol.com](mailto:nuease@aol.com) | TEL: 201.723.8941 | FAX: 1-201-837-9427

**NAVIGATE**

- [NEXT >](#)
- [< BACK](#)
- [INDEX](#)

**ORDERING 1,2,3**

- [HOW TO ORDER](#)
- [PRICE LIST](#)
- [ORDER FORM](#)
- [E-MAIL ORDER](#)

**COMPLETE INDEX**

- [CATALOG INDEX](#)
- [DOWNLOAD PDF CATALOG](#)
- [CONTACT US](#)

**SEND ORDER FORM AS EMAIL ATTACHMENT  
WE WILL PRINT & DELIVER IMMEDIATELY**

MEET THE NEXT GENERATION PRO GARMENT STEAMER. THE AMAZING STEAM BUTLER II, HAS AN UPDATED HEATING ELEMENT FOR EVEN GREATER THRUST! ADVANCED TECHNOLOGY ALLOWS INCREASED PERFORMANCE AND ONE YEAR WARRANTY. THE BEST STEAMER WE HAVE EVER OFFERED! A POWERFUL 1350 WATTS.

USE ON ANY FABRIC  
30 SEC START-UP

1350 WATTS OF POWER!  
AUTO SHUT-OFF

ST500

1 YEAR WARRANTY

#ST500: STEAM BUTLER II  
1350 WATTS, 66" HOSE, 2.6 LITRE BOTTLE, 30 SECOND START-UP



CANVAS GRIP-TITE BAG



VINYL SUIT COVER



ROLLING DUFFLES



ROLLING ZIPPERED CASE



ROLLING HARD CASE

**WARDROBE SUPPLY**

EVERYTHING FOR WARDROBE  
ON LOCATION  
IN STUDIO

NYC NJ DAILY VANG MANHATTAN SINCE 1933

WARDROBE SUPPLY

STEAMER CARRIER

PADDED VINYL

#K1872 CARRY CASE [FOR STEAMER]  
TAKE THE STEAM BUTLER II TO TRADE SHOWS AND LOCATION SHOTS. A TESTAMENT TO ITS VERSATILITY AND DURABILITY. WEIGHS LESS THAN 15 LBS.

STEAM BUTLER II IS SO DURABLE AND LIGHTWEIGHT THAT IT IS PORTABLE!



nuease@aol.com | TEL: 201.723.8941 | FAX: 1-201-837-9427

NAVIGATE

**NEXT>**

**<BACK**

**INDEX**

ORDERING 1,2,3

**HOW TO ORDER**

**PRICE LIST**

**ORDER FORM**

**E-MAIL ORDER**

COMPLETE INDEX

**CATALOG INDEX**

**DOWNLOAD PDF CATALOG**

**CONTACT US**

SEND ORDER FORM AS EMAIL ATTACHMENT  
WE WILL PRINT & DELIVER IMMEDIATELY

## HUMONGOUS DUFFLES: GIANT VALUE - Mini Price!



RDB36WC

RB42

DBT40WC

### LARGE ROLLING DUFFLE

#RDB36WC: ROLLING DUFFLE [36 X 18 X 17"] GREAT SIZE, GOOD CONSTRUCTION AT A GREAT PRICE MAKE THESE ROLLING DUFFLES THE ONE FOR SALESMEN. NUMEROUS POCKETS AND A TELESCOPING HANDLE AND [3] SKATE WHEELS.

FULL BOX QUANTITIES ONLY!  
BOX = 4 DUFFLES

### DROP-BOTTOM TOTE

#DBT40: DROP-BOTTOM TOTE [40 X 24 X 15 1/2"] OVER-SIZED ROLL BAG DROP-BOTTOM ROLLING TOTES UNZIP TWICE TO EXPAND TO FULL SIZE. [6] WHEELS! BALLISTIC POLYTEX  
#RB42: BARREL ROLL BAG [36 X 18"D]

FULL BOX QUANTITIES ONLY!  
BOX = 6 TOTES  
BOX = 12 ROLL BAGS

### WEB STRAPS FOR CASES

#### HEAVY POLY WEB STRAP



WEB72

FITS ALL OUR FIBER CASES

#WEB72: WEB STRAP FULLY ADJUSTABLE LENGTH. FITS ALL OUR TELESCOPE CASES. 1.5" X 78" LONG SEAT-BELT BUCKLE STYLE DURABLE NYLON BUCKLE. HEAVY GAUGE POLY WEB. NON-LOCKING! BLACK

SEAT BELT  
STYLE BUCKLE.

79" LONG STRAP

THESE BAGS ARE THE LARGEST ROLLING DUFFLES OUT THERE! SUPER-TUFF BALLISTIC POLY, REINFORCED AT KEY POINTS WITH WEB. EASY ROLLING TRIPLE & SEXTUPLE SKATE WHEELS! SO BIG, SO STRONG, YET SO INEXPENSIVE THAT YOU CAN "USE'EM AND LOSE'EM"!

### RELATED ITEMS



CANVAS GRIP-TITE BAG



VINYL SUIT COVER



ROLLING ZIPPERED CASE



ROLLING HARD CASE



PROP CASES



WARDROBE SUPPLY

nuease@aol.com | TEL: 201.723.8941 | FAX: 1-201-837-9427

#### NAVIGATE

NEXT >

< BACK

INDEX

#### ORDERING 1,2,3

HOW TO ORDER

PRICE LIST

ORDER FORM

E-MAIL ORDER

#### COMPLETE INDEX

CATALOG INDEX

DOWNLOAD PDF CATALOG

CONTACT US

SEND ORDER FORM AS EMAIL ATTACHMENT  
WF WII | PRINT & DEL FTF IMMEDIATELY



## THE ULTIMATE SOFT-SIDE SAMPLE CASE!

THE STRENGTH OF OUR HARD FIBER CASES IN THE SKIN OF A LIGHT, CONVENIENT AND ATTRACTIVE SOFT-SIDE SAMPLE CASE. AS DESIGNER, WE CAN OFFER THESE ZIPPER-CASES AT LOW, DIRECT PRICES!

ASSEMBLED IN THE USA!



SUPER-GEL CASTERS

GH29WC  
GH32WC

THE ORIGINAL ZIPPERED SAMPLE CASE IS NOW EVEN BETTER! RE-DESIGNED AND REINFORCED WITH ITS HEX-CELL HONEYCOMB AND STEEL BANDED FRAME PLUS PVC REINFORCED SOFT-SIDES. SUPER-GEL CASTERS FOR FEATHER TOUCH ROLLING!

STYLE NO. DIMENSIONS DESCRIPTION WHEEL SIZE  
#GH32WC 32 X 23 X 11" JUMBO PULLMAN 3" CASTERS  
#GH29WC 29 X 22 X 10" JUNIOR PULLMAN 3" CASTERS  
COLOR: BLACK NYLON WITH BLACK 2" WEB STRIPE

DOUBLE-REINFORCED FRAME:  
COMBINATION STEEL BANDED HONEYCOMB, HEX-CELL FRAME. LATEST TECHNOLOGY, FOR A DURABLE BAG SUPPORT SYSTEM!

REINFORCED SOFT-SIDE:  
A HARD PVC PANELS REINFORCE THE SOFT-SIDES FOR SHAPE RETENSION AND TREMENDOUS IMPACT RESISTANCE!

SELF-REPAIRING ZIPPER:  
#10 NYLON COIL SELF-REPAIRING ZIPPER. SUPERIOR FOR ITS ABILITY TO FIX MOST PROBLEMS BY RE-ZIPPING.

FOUR-WHEEL DRIVE [3" CASTERS]:  
ROLLS UPRIGHT ON [4] LARGE THREE INCH SUPER-GEL WHEELS. HEAVY-DUTY, BACK-SAVING, FINGERTIP ROLLING EASE. USE THIS BAG JUST ONCE, IT WILL BE UNTHINKABLE TO GO BACK TO "OLD-FASHIONED" LUGGAGE!

BALLISTIC NYLON MATERIAL: 1050D BALLISTIC NYLON IS USED FOR ITS SUPREME DURABILITY. THE "KING" OF WOVEN FABRICS, COVETED FOR ITS SMART LOOKS AND UNCANNY STRENGTH. SO STRONG . . . IT'S USED BY LAW ENFORCEMENT!.

REMOVABLE LINING & INSIDE WEB STRAPS:  
SKID PLATES & SCUFF STRIPS:  
PROTECT ZIPPER, EDGE BINDING AND MATERIAL FROM DAMAGE.

CASES DAMAGED BY AIRLINES OR PARCEL SERVICES ARE CONSIDERED TO BE CLAIMS WITH THOSE ENTITIES, NOT WARRANTEE ISSUES!

### RELATED ITEMS



CANVAS GRIP-TITE BAG



ROLLING HARD CASE



PROP CASES



FOLDING ROLLING RACK



BIG WHEELER



FOLDING TRIPOD RACK

[nuease@aol.com](mailto:nuease@aol.com) | TEL: 201.723.8941 | FAX: 1-201-837-9427

#### NAVIGATE

[NEXT >](#)

[< BACK](#)

[INDEX](#)

#### ORDERING 1,2,3

[HOW TO ORDER](#)

[PRICE LIST](#)

[ORDER FORM](#)

[E-MAIL ORDER](#)

#### COMPLETE INDEX

[CATALOG INDEX](#)

[DOWNLOAD PDF CATALOG](#)

[CONTACT US](#)

[SEND ORDER FORM AS EMAIL ATTACHMENT](#)

OUR SAMPLE CASES ARE MADE OF HEAVYWEIGHT .090 GAUGE "POLY" PLASTIC, WHICH IS A "NEW TECH" MATERIAL THAT IS DURABLE, WARP RESISTANT, PUNCTURE PROOF, WATERPROOF AND HAS AN ATTRACTIVE TEXTURED FINISH THAT EASILY WIPES CLEAN. THIS HARDENED MATERIAL IS LIGHTWEIGHT, BUT VERY STRONG AND IS REINFORCED WITH HEAVY SOLID STEEL CORNERS, CLAMPS AND FRAMES TO MAKE THESE POUND FOR POUND THE STRONGEST, LONGEST LASTING CASES ON THE MARKET. DURABILITY IS WHAT SAVES YOU CASH!



**SUPER-TUFF HARDENED POLY**

501A3020WC 501A30WC

501A4020WC 501A3620WC 501A3220WC

**AMAZING SUPER-GEL WHEELS**

**SUPER**



**POUND FOR POUND THE TOUGHEST CASE FOR AIRLINES AND UPS / FEDEX TRANSPORT!**

**HUGE ADJUSTABLE CAPACITY!**

**BACK-SAVING FOUR WHEEL DRIVE FOR UPRIGHT EASY ROLLING!**

**SUPER-GEL WHEELS FOR FEATHER TOUCH GLIDE. ULTRA-LONG LASTING!**



**CANVAS GRIP-TITE BAG**



**PROP CASES**



**FOLDING ROLLING RACK**



**BIG WHEELER**



**FOLDING TRIPOD RACK**

**STOCK SIZES**

**ROLLING SUITCASES**

**HARD FIBER / SOFT**

- #501A: TELESCOPE CASES
- #501A30WC [30X18X10"] CASTERS
- #501A3020WC [30X20X16"] CASTERS
- #501A3220WC [32X20X15"] CASTERS
- #501A3620WC [36X20X12"] CASTERS
- #501A4020WC [40X20X12"] CASTERS

- #551A: SUITCASE STYLE
- #551A3620WC [36X20X12"] CASTERS

**HUGE INVENTORY!  
100'S OF CASES  
IN STOCK FOR  
DELIVERY AT ONCE!**

CASES DAMAGED BY AIRLINES OR PARCELS SERVICES, ARE CONSIDERED TO BE CLAIMS WITH THOSE ENTITIES, NOT WARRANTY ISSUES!



551A3620WC

#551A3620: HINGED LID. POLY MATERIAL IS REINFORCED WITH SOLID STEEL FRAME AND CORNERS, HEAVY-DUTY LATCHES AND PADDED HANDLES. SUPER-GEL WHEELS.



NOT AVAILABLE

**nuease@aol.com | TEL: 201.723.8941 | FAX: 1-201-837-9427**

**NAVIGATE**

- NEXT >**
- < BACK**
- INDEX**

**ORDERING 1,2,3**

- HOW TO ORDER**
- PRICE LIST**
- ORDER FORM**
- E-MAIL ORDER**

**COMPLETE INDEX**

- CATALOG INDEX**
- DOWNLOAD PDF CATALOG**
- CONTACT US**

**SEND ORDER FORM AS EMAIL ATTACHMENT**



**WARDROBE SUPPLY**

WARDROBE CASES



#301MP: ROLLING PROP CASE [26 X 16 X 11"] HAS [6] 4" HIGH DRAWERS AND [4] 3" WHEELS. USED FOR PROPS, MAKE-UP OR JEWELRY. 3" CASTERS

#400JC/30: SHORT DOOR [30" HIGH] JEWELRY CASE HAS DOOR ON NARROW SIDE, [2] SHELVES AND HOLDS [26] 1" TRAYS. 3" CASTERS.

#501A/HAT: TELESCOPING HAT CASE [18 X 36"] REMOVABLE LID. FOR BRIMMED HATS.

SUPER CASES



551A/SUPER  
501A/SUPER

ALUMINUM VALANCE, HEAVY-DUTY LATCHES

JUMBO 4" GEL WHEELS

**SUPER**

#551A/SUPER: SUPER-SUITCASE [36 X 20 X 12"] .125 GA. GREY "POLY" FOR UNMATCHED STRENGTH. ALUMINUM VALANCE FOR SHAPE RETENSION AND EASY CLOSURE, HEAVY DUTY LOCKS AND HARDWARE, PLUS [5] GIANT 4" SUPER CASTERS FOR EASY ROLLING.

#501A/SUPER: SUPER TELESCOPE CASE [40 X 20 X 10"] MADE OF .125 GA. "POLYTUFF" PLASTIC IN THE TELESCOPE STYLE. HAS [3] WEB STRAPS, HEAVY-DUTY HARDWARE AND JUMBO SUPER-GEL 4" CASTERS.

RELATED ITEMS



FOLDING ROLLING RACK



BIG WHEELER



FOLDING TRIPOD RACK



FOLDING SCREEN



SHOW LIGHT

JEWELRY TRAYS & PADS

BLACK LEATHERETTE / VELVET



TRAYS & SNAP



BLACK VELVET



PADDED CARRIER

#K1272: HOLDS [12] 1" TRAYS  
#K1872: HOLDS [18] 1" TRAYS [TRAYS NOT INCLUDED]  
LIGHTWEIGHT CARRY CASE WATER AND WEAR RESISTANT GREY FABRIC WITH BLACK WEBBED HANDLE AND TRIM. HEAVILY PADDED. ZIPPERS AND VELCRO SIDE CLOSURE.

VELVET PADS: FIT STANDARD TRAYS  
#VP200: VELVET PAD - PLAIN  
#222-1: RING PAD  
#BX640-BK: BRACELET/ WATCH  
#92-E3: EARRING PAD  
#93BK: CHAIN [6 SNAPS]  
#96-18: PENDANT [18 COMP.]

TRAYS & TRAYS WITH SNAP COVERS  
#T200: TRAY [14 1/4 X 8 1/4 X 1"]  
#T200/2: TRAY [14 1/4 X 8 1/4 X 2"]  
#T200/SP: W/ COVER [14 1/4 X 8 1/4 X 1"]  
#T200/2SP: W/ COVER [14 1/4 X 8 1/4 X 2"]  
BLACK LEATHERETTE



WARDROBE SUPPLY

nuease@aol.com | TEL: 201.723.8941 | FAX: 1-201-837-9427

NAVIGATE

- [NEXT >](#)
- [< BACK](#)
- [INDEX](#)

ORDERING 1,2,3

- [HOW TO ORDER](#)
- [PRICE LIST](#)
- [ORDER FORM](#)
- [E-MAIL ORDER](#)

COMPLETE INDEX

- [CATALOG INDEX](#)
- [DOWNLOAD PDF CATALOG](#)
- [CONTACT US](#)

SEND ORDER FORM AS EMAIL ATTACHMENT

WE WILL PRINT & DELIVER IMMEDIATELY

DON'T CONFUSE THESE RACKS WITH OTHERS ON THE MARKET! OUR RACKS ARE MADE EXCLUSIVELY TO OUR SPECIFICATIONS TO ENSURE OUR CUSTOMERS OF THE LONGEST LASTING, EASIEST TO USE COLLAPSIBLE RACKS AVAILABLE TODAY! COMPETITORS, TO COMPETE WITH OUR HAVE CUT CORNERS WITH LIGHTER GAUGE TUBING AND NON-REINFORCED LEGS.

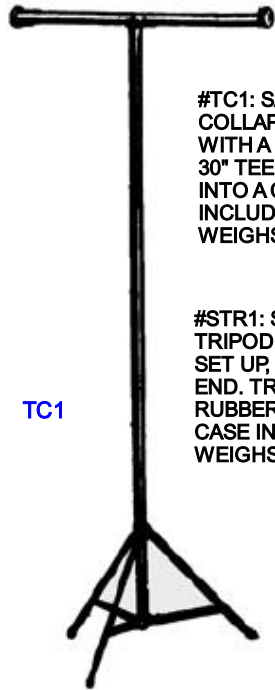

TC1

#TC1: SALESMEN'S TEE STAND  
COLLAPSIBLE TRIPOD TEE STAND  
WITH A SINGLE TRIPOD BASE AND A  
30" TEE TOP. KNOCKS DOWN EASILY  
INTO A COMPACT CASE WHICH IS  
INCLUDED.  
WEIGHS JUST 7 LBS!

#STR1: SALESMEN'S COLLAPSIBLE  
TRIPOD RACK. 64" HIGH, 5' LONG WHEN  
SET UP, WITH 12" PULLOUTS AT EACH  
END. TRIPOD LEGS HAVE  
RUBBER TIPS. ZIPPERED CARRYING  
CASE INCLUDED.  
WEIGHS ONLY 16 LBS!

EXCLUSIVE!

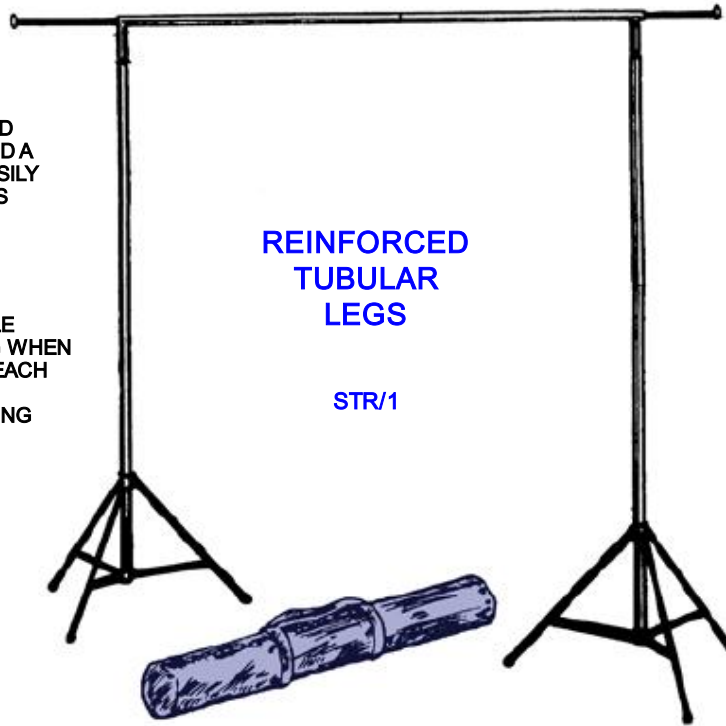

REINFORCED  
TUBULAR  
LEGS

STR/1

CARRY CASE  
FREE!



FOLDING ROLLING RACK



BIG WHEELER



SHOW LIGHT

RACK ACCESSORIES

CENTER ADJUSTABLE HANGRAILS

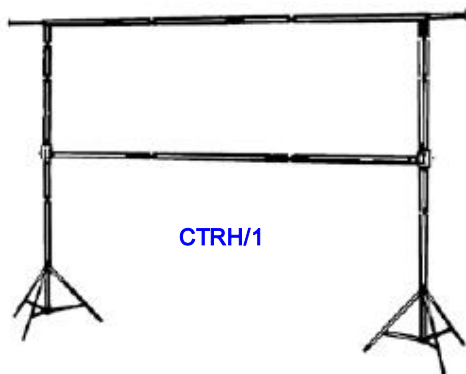

CTRH/1

EXCLUSIVE!

HEIGHT EXTENDERS: 12"H  
#HE12 [FOR: SWF & STR1]  
CENTER ADJUSTABLE HANGRAILS:  
#CTRH [FOR: STR1]



CTRH/2

EXCLUSIVE!

HEIGHT EXTENDERS: 12"H  
#HE12 [FOR: SWF & STR1]  
CENTER ADJUSTABLE HANGRAILS:  
#CTRH [FOR: STR1]



SAS/1

#SAS1: SPACE-AIDE SET  
SCREEN FOLDS TO FIT THE BASE. RACK  
CAN BE FOLDED WITH SCREEN. FITS #SWF  
& BW5. GARMENTS AND SCREEN FIT ON  
ONE RACK.  
SIZE: 45"L X 36"H/ FOLDED: 18"H



CHROME WIRE HANGER



PLASTIC HANGERS



WOOD HANGERS

nuease@aol.com | TEL: 201.723.8941 | FAX: 1-201-837-9427

NAVIGATE

NEXT >

< BACK

INDEX

ORDERING 1,2,3

HOW TO ORDER

PRICE LIST

ORDER FORM

E-MAIL ORDER

COMPLETE INDEX

CATALOG INDEX

DOWNLOAD PDF CATALOG

CONTACT US

SEND ORDER FORM AS EMAIL ATTACHMENT  
WE WILL PRINT & DELETE IMMEDIATELY

DO NOT CONFUSE THE RACKS ON THIS PAGE WITH ANY OTHERS ON THE MARKET! OUR RACKS ARE MADE EXCLUSIVELY TO OUR SPECIFICATIONS TO INSURE THE LONGEST LASTING, EASIEST TO USE COLLAPSIBLE RACKS AVAILABLE TODAY! COMPETITORS USE LIGHTER GAUGE TUBING AND NON-REINFORCED BASE SECTIONS.

NOW, BETTER THAN EVER!  
**\*\*THICKER GAUGE TUBING**  
**\*\*REINFORCED PULLOUTS**  
**\*\*EVEN BETTER WHEELS**  
**\*\*NO EXTRA COST**

#SWF-ADJ: FOLDING WHEELABOUT RACK  
 16 GAUGE ROUND TUBING, HELI-ARC WELDED, END BASE SECTIONS REINFORCED WITH SOLID STEEL BARS. TRIPLE CHROME PLATED FOR AN ALL-WEATHER FINISH. REINFORCED 12" PULLOUTS. ADJUSTABLE HEIGHT. COLLAPSES EASILY TO FIT CAR TRUNKS. HIGH QUALITY 4" DOUBLE BALL BEARING CASTERS.

SIZE: 48 X 22 X 54-64"  
 FOLDED: 48 X 22 X 5"

FOLDS FLAT IN SECONDS!



BUY THE ORIGINAL,  
 BUY THE BEST!

SWF-adj



SHOW LIGHT



CHROME WIRE HANGER



PLASTIC HANGERS



VELVET HANGERS



CONTOUR PLASTIC

THE "BIG WHEELER"

SQUARE TUBING, CHROME



BW5-adj

**SUPER**  
 5" JUMBO WHEELS

WHEN YOU NEED THE BEST ...  
 BUY OUR STRONGEST, EASIEST  
 ROLLING COLLAPSIBLE RACK!

HEAVY LINES NEED OUR "BIG WHEELER", TO EASE YOUR BURDEN LIKE NO OTHER !! HOWEVER, BEING 8 LBS. HEAVIER THAN THE "WHEELABOUT", THIS RACK IS NOT FOR EVERYONE, BUT FOR THOSE WHO NEED THE ULTIMATE IN STRENGTH AND FUNCTION, THE "BIG WHEELER" IS THE BEST . . . BAR NONE!

#BW5-ADJ: FOLDING "BIG WHEELER"  
 HEAVY-DUTY 16 GAUGE SQUARE TUBING, 25% STRONGER THAN ROUND. HELI-ARC WELDED AND TRIPLE CHROME PLATED. END BASE SECTIONS ARE REINFORCED WITH SOLID STEEL BARS. [12"] LOCKING PULLOUTS. JUMBO 5" SUPER-GEL CASTERS FOR THE EASIEST ROLLING WHEELS ON THE MARKET. FOLDS FLAT EASILY. ADJUSTABLE IN HEIGHT: 54-64".

SIZE: 48 X 22 X 54-64" FOLDED: 50 X 22 X 5"



WARDROBE SUPPLY

nuease@aol.com | TEL: 201.723.8941 | FAX: 1-201-837-9427

NAVIGATE

- [NEXT >](#)
- [< BACK](#)
- [INDEX](#)

ORDERING 1,2,3

- [HOW TO ORDER](#)
- [PRICE LIST](#)
- [ORDER FORM](#)
- [E-MAIL ORDER](#)

COMPLETE INDEX

- [CATALOG INDEX](#)
- [DOWNLOAD PDF CATALOG](#)
- [CONTACT US](#)

SEND ORDER FORM AS EMAIL ATTACHMENT  
 WE WILL PRINT & DELETE IMMEDIATELY

SHO-LITES ARE THE MOST POWERFUL, PORTABLE AND PROFESSIONAL ILLUMINATION FOR TRADE SHOWS AND FASHION PRESENTATIONS. THESE NOVEL LED UNITS PROVIDE THE PERFECT COLOR REGISTRATION NEEDED TO SHOW GARMENTS IN THEIR "TRUE LIGHT". ONLY THESE UNITS HAVE THE FEATURES TO HANDLE THE UNIQUE DEMANDS OF THE APPAREL SALESMAN!



LB500: COMPACT LIGHTING / 500WATT UNIT IS A LIGHTWEIGHT VIDEO FLOOD THAT IS IDEAL FOR LIGHTING AT TRADE SHOWS, WHETHER IN HOTEL ROOMS OR OPEN BOOTH SHOWS. LED LIGHTS LAST 40K HOURS. CAN BE USED WITH A TRIPOD OR CLAMP. HAS A 3/8-5/8" UNIVERSAL MOUNT, 10 FT. GROUNDED LINE WITH AN IN-LINE SWITCH. U/L RATED.

LB1000: PRO STUDIO SET TOTALS 1000 WATTS OF LIGHT 2 - LB500, 2-WW STANDS, 1-CARRIER GREAT VALUE, A SIMPLER WAY TO LIGHT A BOOTH!



CANVAS GRIP-TITES



CHROME WIRE HANGER



PLASTIC HANGERS



WOOD HANGERS



VELVET HANGERS



CONTOUR PLASTIC

SHO-LITE ACCESSORIES      QUARTZ-HALOGEN BULBS

TRIPOD STAND



GAFFER CLAMP



#48: GAFFER CLAMP CAN BE USED WITH EITHER THE #QL600 OR #QLITE TO MOUNT ON TUBING OR ANY CONVENIENT SURFACE. MAKE SURE TO CLAMP UNIT AWAY FROM ANY FLAMMABLE MATERIALS!

#WW: WELTERWATE TRIPOD IS SUITABLE FOR EITHER UNIT. EXTENDS HIGH ENOUGH FOR LIGHT TO BE BOUNCED OFF CEILING FOR BETTER DISPERSION. ADJUSTS 24 TO 84" HIGH. HEAVY-DUTY ALUMINUM.

600 WATT



500-1000 WATT



ITEM NO. WATTAGE USED FOR BULB LIFE  
 #600W 600 WATTS #QL600 75 HOURS  
 #500W 500 WATTS #QLITE 2000 HOURS  
 #1000W 1000 WATTS #QLITE 400 HOURS

nuease@aol.com | TEL: 201.723.8941 | FAX: 1-201-837-9427

- NAVIGATE
- NEXT >
  - < BACK
  - INDEX

- ORDERING 1,2,3
- HOW TO ORDER
  - PRICE LIST
  - ORDER FORM
  - E-MAIL ORDER

- COMPLETE INDEX
- CATALOG INDEX
  - DOWNLOAD PDF CATALOG
  - CONTACT US

SEND ORDER FORM AS EMAIL ATTACHMENT  
 WE WILL PRINT & DELETE IMMEDIATELY

SHOULDER SHAPED HANGER

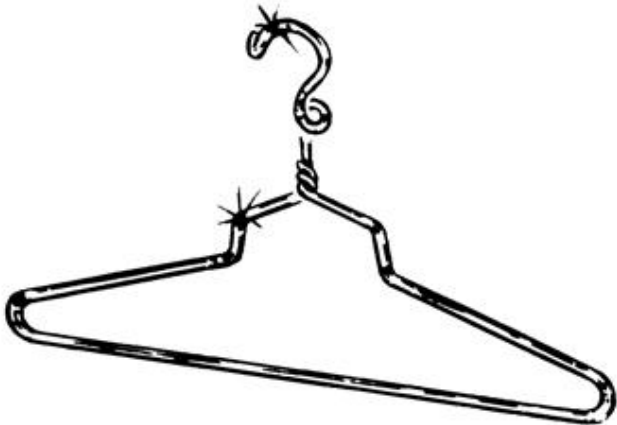

#213SB14 TEEN / JUNIOR  
 #213SB16 LADIES BLOUSE  
 #213SB18 MENS JACKET  
 #213SB19 MENS COAT

**\*\* CONSUMER ALERT \*\***

OUR CHROME WIRE HANGERS ARE TRIPLE CHROME PLATED 10 GAUGE WIRE. SOME WEB MERCHANTS HAVE GONE TO A THINNER 11 GAUGE WIRE TO SAVE COST. THE LIGHTER GAUGE HANGERS TEND TO BEND AND CAN LOSE THEIR HOOKS.

**\*\* ORDERING HANGERS \*\***

HANGER WIDTH FOR GARMENT SIZE  
 14" WIDTH . . . TEEN [7-14]  
 16" WIDTH . . . LADIES  
 18" WIDTH . . . MEN'S  
 19" WIDTH . . . MEN'S COAT/ XL

Please Specify "SB" or "REG"  
 for Style of Hook and Size of Hanger  
 E.G.: #213SB16, #245SB12  
 OR #213REG16, #245REG12



CANVAS GRIP-TITES



VELVET HANGERS

SKIRT / SLACK HANGER



#245SB12 SKIRT / PANT

LINGERIE HANGER

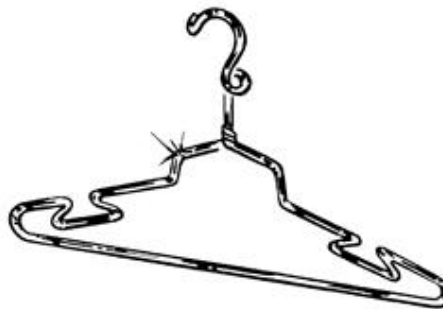

#312SB16 LINGERIE



PLASTIC HANGERS

SUIT / SLACK HANGER

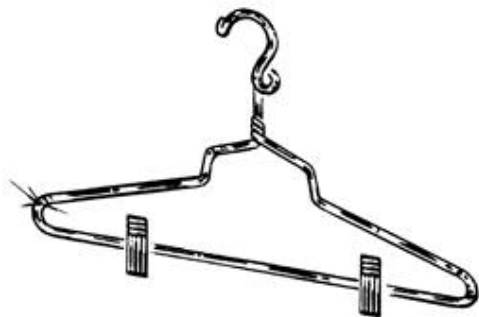

#219SB16 SUIT / SLACK

NON-SLIP KNIT HANGER



#112SB NON-SLIP KNIT



WOOD HANGERS



CONTOUR PLASTIC

nuease@aol.com | TEL: 201.723.8941 | FAX: 1-201-837-9427

NAVIGATE

- [NEXT >](#)
- [< BACK](#)
- [INDEX](#)

ORDERING 1,2,3

- [HOW TO ORDER](#)
- [PRICE LIST](#)
- [ORDER FORM](#)
- [E-MAIL ORDER](#)

COMPLETE INDEX

- [CATALOG INDEX](#)
- [DOWNLOAD PDF CATALOG](#)
- [CONTACT US](#)

WARDROBE SUPPLY



WARDROBE SUPPLY

SEND ORDER FORM AS EMAIL ATTACHMENT  
 WE WILL PRINT & DELETE IMMEDIATELY

HIGH QUALITY, LOW COST FORMS . INJECTION MOLDED HALF-ROUND FORMS FEATURING A DURABLE, YET LIGHTWEIGHT CONSTRUCTION. EASY AND ECONOMICAL TO DISPLAY FORMS WITH THE CHROME HOOKS INCLUDED. A GREAT VALUE . . . ITS LIKE HAVING A MANNEQUIN ON A HOOK!



#LHR15 WOMENS  
#MHR26 MENS  
[B] BLACK  
[W] WHITE

#FHR17 PLUS SIZE  
#BHR5 TEEN BOY  
#GHR6 TEEN GIRL

#LHR32 HIP FORM  
#LHR35 BRA FORM

SELECT COLOR  
BY INDICATING:  
[B] BLACK  
[W] WHITE

FULL BOXES  
ONLY PLEASE:  
BOX=12 PCS



CANVAS GRIP-TITES



VELVET HANGERS



PLASTIC HANGERS

VELVET SLIM-LINE HANGERS

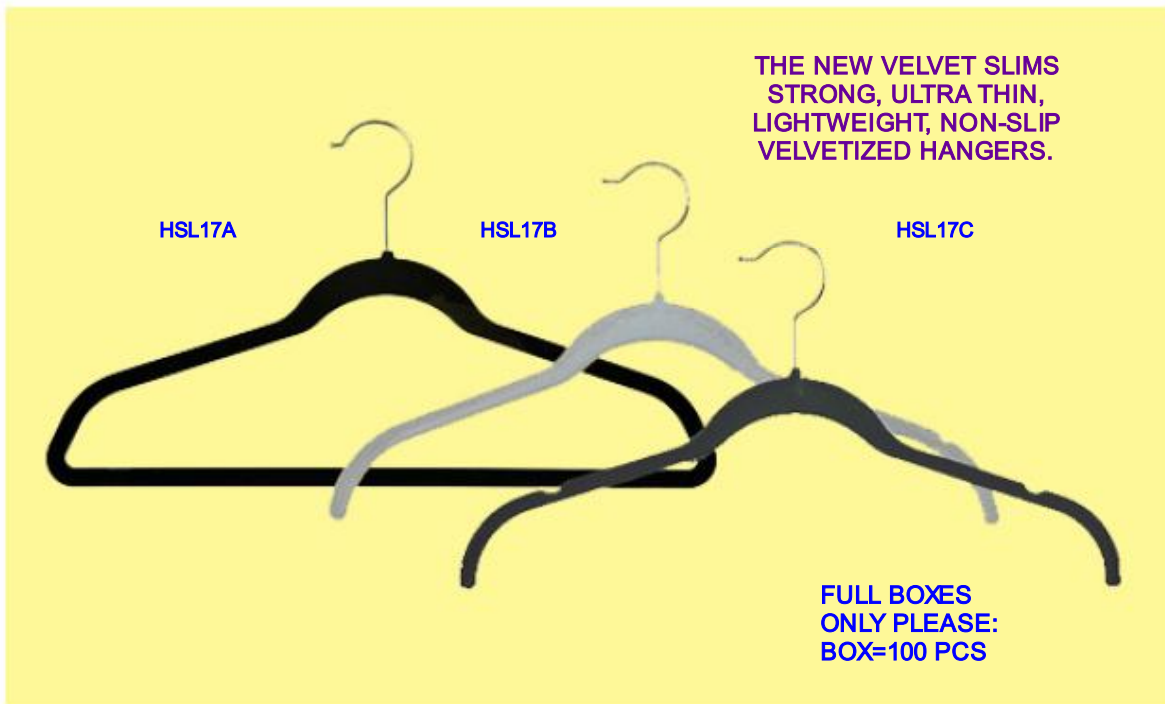

THE NEW VELVET SLIMS  
STRONG, ULTRA THIN,  
LIGHTWEIGHT, NON-SLIP,  
VELVETIZED HANGERS.

DISPLAY MORE  
GOODS IN A  
SMALLER SPACE.  
VELVET FINISH  
IS PERFECT  
FOR LINGERIE  
AND KNITWEAR!

HSL17A:  
SUIT HANGER  
HSL17B:  
BLOUSE HANGER  
HSL17C:  
DRESS HANGER

17 X 3/8" SLIM  
DESIGN

CHROME SWIVEL  
HOOK

FULL BOXES  
ONLY PLEASE:  
BOX=100 PCS



WOOD HANGERS



CONTOUR PLASTIC



ROLLING GRID RACK

nuease@aol.com | TEL: 201.723.8941 | FAX: 1-201-837-9427

NAVIGATE

- NEXT >
- < BACK
- INDEX

ORDERING 1,2,3

- HOW TO ORDER
- PRICE LIST
- ORDER FORM
- E-MAIL ORDER

COMPLETE INDEX

- CATALOG INDEX
- DOWNLOAD PDF CATALOG
- CONTACT US

SEND ORDER FORM AS EMAIL ATTACHMENT  
WE WILL PRINT & DELETE IMMEDIATELY



SUPER-HEAVYWEIGHT, VERY DURABLE, PREMIUM QUALITY MOLDED HANGERS ARE THE HEAVIEST ON THE MARKET. THE BLACK HANGERS ARE MIXED WITH A HIGH-IMPACT RESIN THAT RENDERS THEM ALMOST UNBREAKABLE!

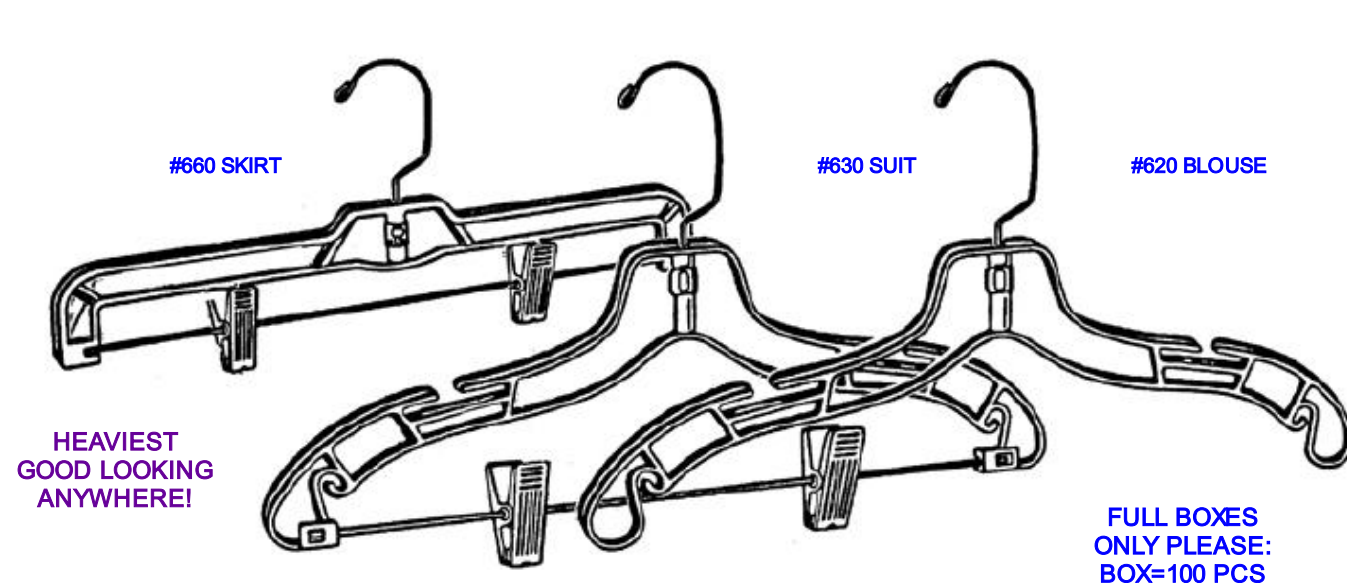

#660 SKIRT

#630 SUIT

#620 BLOUSE

HEAVIEST  
GOOD LOOKING  
ANYWHERE!

FULL BOXES  
ONLY PLEASE:  
BOX=100 PCS

CRYSTAL CLEAR SUPER-HEAVYWEIGHT  
#620 - 17" BLOUSE / DRESS  
#630 - 17" SUIT / SLACK / SKIRT  
#660 - 14" PANT / SKIRT

ALSO AVAILABLE:  
#670 - 14" JR. BLOUSE / DRESS  
#840 - 12" 14" CHILD BLOUSE / DRESS  
#660/12 - 12" JR. / TEEN PANT / SKIRT



CHROME WIRE HANGER



WOOD HANGERS



CONTOUR PLASTIC

BLACK PLASTIC HANGERS

SEMI-GLOSS / BLACK

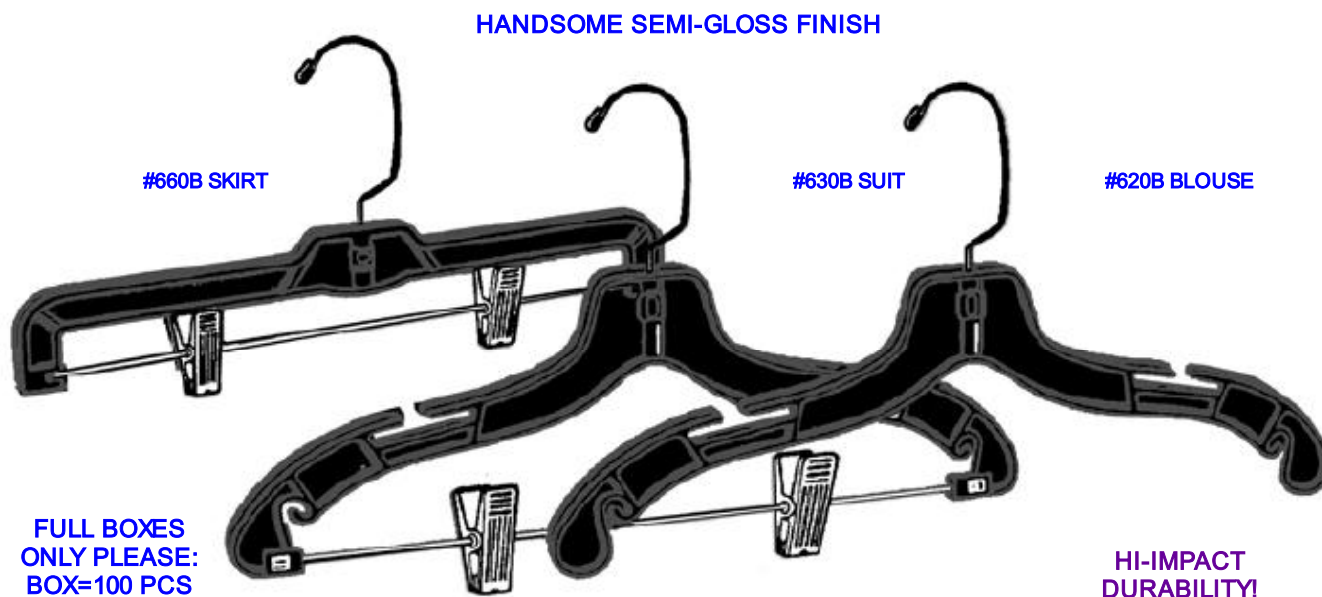

#660B SKIRT

#630B SUIT

#620B BLOUSE

HANDSOME SEMI-GLOSS FINISH

FULL BOXES  
ONLY PLEASE:  
BOX=100 PCS

HI-IMPACT  
DURABILITY!

BLACK SUPER-HEAVYWEIGHT  
#620B - 17" BLACK BLOUSE / DRESS  
#630B - 17" BLACK SUIT  
#660B - 14" BLACK PANT / SKIRT

BLACK SUPER-HEAVYWEIGHT HANGERS  
VIRGIN PLASTIC MIXED WITH A HIGH IMPACT  
RESIN FOR GREATEST DURABILITY.



ROLLING GRID RACK



SHOWROOM RACKS

nuease@aol.com | TEL: 201.723.8941 | FAX: 1-201-837-9427

NAVIGATE

NEXT>

<BACK

INDEX

ORDERING 1,2,3

HOW TO ORDER

PRICE LIST

ORDER FORM

E-MAIL ORDER

COMPLETE INDEX

CATALOG INDEX

DOWNLOAD PDF CATALOG

CONTACT US

WARDROBE SUPPLY



WARDROBE SUPPLY

SEND ORDER FORM AS EMAIL ATTACHMENT  
WE WILL PRINT & DELIVER IMMEDIATELY

FINE QUALITY NATURAL WOOD CONCAVE WOOD HANGERS ARE LUXURIOUS LACQUERED FINISH, CONTOURED TO SHOW-OFF YOUR GARMENTS. THE NATURAL IS COMPLIMENTED WITH CHROME HARDWARE TO ADD LUSTER THAT TO YOUR LINE, WITHOUT THE COST! BLACK IS ALSO IN STOCK. WALNUT FINISH AT A CLEARANCE PRICE!

HANDSOME NATURAL WOOD SEMI-GLOSS FINISH

#WB17NB



FULL BOXES  
ONLY PLEASE:  
BOX=100 PCS

#WB17NB: JACKET ½ X 17"  
WISHBONE SHAPE  
NATURAL FINISH  
CHROME HOOK

#WB17

WEB SALE  
\$69.00



#WB17: SUIT W/ BAR ½ X 17"  
WISHBONE SHAPE  
NATURAL FINISH  
CHROME HOOK

#WB14SK



#WB14SK: SKIRT W/ CLIPS ½ X 14"  
NATURAL FINISH  
CHROME HARDWARE

NATURAL WOOD SEMI-GLOSS

#W75



FULL BOXES  
ONLY PLEASE:  
BOX=100 PCS

#WB75: DRESS 3/8 X 17"  
SHOULDER NOTCHES  
NATURAL FINISH  
CHROME HOOK

LUXURIOUS WALNUT SEMI-GLOSS FINISH

#WB17W

WEB SALE  
\$69.00



#WB17W: SUIT W/ BAR ½ X 17"  
WISHBONE SHAPE  
WALNUT FINISH  
BRASS HOOK

#WB14WSK

WEB SALE  
\$69.00



#WB14WSK: SKIRT W/ CLIPS ½ X 14"  
WALNUT FINISH  
BRASS HARDWARE

BLACK SEMI-GLOSS FINISH

#W75B



#WB75B: DRESS 3/8 X 17"  
SHOULDER NOTCHES  
BLACK FINISH

#WB17NB

FULL BOXES  
ONLY PLEASE:  
BOX=100 PCS



#WB17NB: JACKET ½ X 17"  
WISHBONE SHAPE  
BLACK FINISH

#WB14BSK



#WB14BSK: SKIRT W/ CLIPS ½ X 14"  
BLACK FINISH  
BLACK HARDWARE



CHROME WIRE HANGER



PLASTIC HANGERS



CONTOUR PLASTIC



ROLLING GRID RACK



BLACK GRID DISPLAY

nuease@aol.com | TEL: 201.723.8941 | FAX: 1-201-837-9427

NAVIGATE

NEXT>

<BACK

INDEX

ORDERING 1,2,3

HOW TO ORDER

PRICE LIST

ORDER FORM

E-MAIL ORDER

COMPLETE INDEX

CATALOG INDEX

DOWNLOAD PDF CATALOG

CONTACT US

WARDROBE SUPPLY



WARDROBE SUPPLY

SEND ORDER FORM AS EMAIL ATTACHMENT  
WE WILL PRINT & DELIVER IMMEDIATELY

ELEGANT AND AFFORDABLE, OUR DISPLAY HANGERS ARE THE ULTIMATE FOR SHOWING LADIES OR MENS COATS, SWEATERS, TOPS OR DRESSES. HIGH NECKLINES AND 1-1/2" DEEP SHOULDER CONTOURS ALLOW GARMENTS TO DRAPE PERFECTLY, WITHOUT SLIPPING OR CREASING. YOUR BEST GARMENTS DESERVE THE BEST HANGERS.

ELEGANT CONTOUR JACKET AND DRESS HANGER

SHOW-OFF COORDINATES!



CHROME WIRE HANGER



PLASTIC HANGERS



ROLLING GRID RACK



ROLLING LADDER RACK



BLACK GRID DISPLAY



SHOWROOM RACKS

THE BEST SHAPE FOR THE BEST DRAPE!

#TL16



#TL16: LADIES - 16 X 1 1/2" CONTOUR DISPLAY HANGER

#TL16SK2: 16 X 1 1/2" X 2" DROP  
#TL16SK10: 16 X 1 1/2" X 10" DROP

BEAUTIFUL BLACK SEMI-GLOSS FINISH

FULL BOXES ONLY PLEASE:  
BOX=100 PCS

BLACK EPOXY HANGERS

BLACK / BLACK HOOK

DE-LUXE ALL-BLACK HANGERS IN A SEMI-GLOSS FINISH

#620BXY: DRESS HANGER [BLACK/ BLACK HOOK]  
#660BXY: SKIRT HANGER [BLACK/ BLACK HOOK]

SUPER-HEAVYWEIGHT, SEMI-GLOSS PLASTIC HANGERS WITH BLACK EPOXY HOOKS. COORDINATES WITH OUR CONTOUR PLASTIC HANGERS.

BLACK HOOKS WITH BLACK BARS AND CLIPS

#620BXY BLACK DRESS  
#660BXY BLACK SKIRT

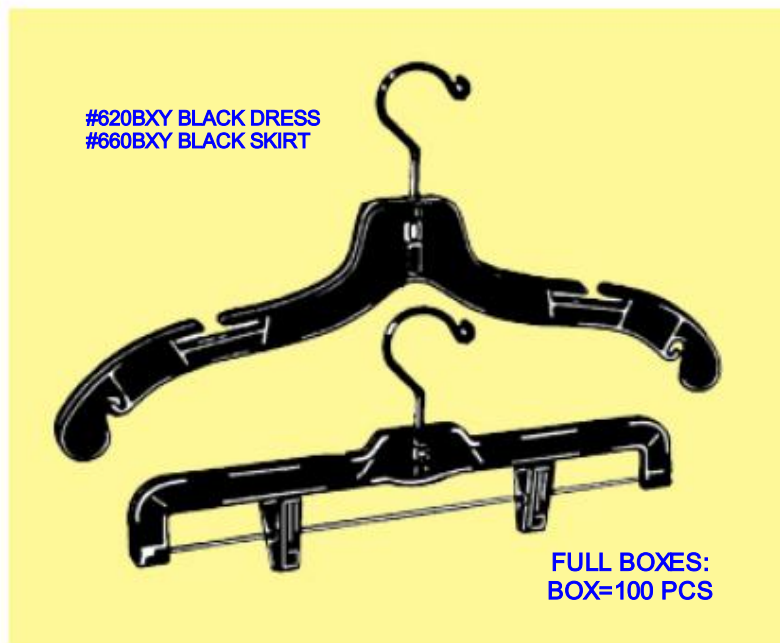

FULL BOXES: BOX=100 PCS

nuease@aol.com | TEL: 201.723.8941 | FAX: 1-201-837-9427

NAVIGATE

NEXT >

< BACK

INDEX

ORDERING 1,2,3

HOW TO ORDER

PRICE LIST

ORDER FORM

E-MAIL ORDER

COMPLETE INDEX

CATALOG INDEX

DOWNLOAD PDF CATALOG

CONTACT US

SEND ORDER FORM AS EMAIL ATTACHMENT  
WE WILL PRINT & DELETE IMMEDIATELY

MAGNIFICENT ROLLING SHOWROOM DISPLAY RACKS



UPS SHIPPABLE

#CDC5X



#GDC2X  
#GDC2X/5L

DESIGNED FOR EASY ASSEMBLY AND EASY SHIPPING NATIONWIDE!

#CDC5X: TWO-SIDED SIX-TIER RACK TWO-SIDED 'A'-FRAME UNIT HAS 1" SQUARE TUBULAR FRAMES WITH SIX-TIERED LADDER DISPLAY AREAS ON BOTH SIDES. COMPLETE WITH 12" PULLOUTS AND 2½" TWIN WHEEL CASTERS. UPS SHIPPABLE!!  
SIZE: 5'L X 21"W X 66"H FINISH: ALL CHROME

UPS SHIPPABLE

#GDC2X: TWO-SIDED GRID RACK / 4'L X 66"H  
#GDC2X/5L: TWO-SIDED GRID RACK / 5'L X 66"H TWO-SIDED 'A'-FRAME RACK HAS TWO 1" SQUARE TUBULAR END PANELS CONNECTED TO 4' X 5" GRID PANELS MADE OF ¼" ROD IN A 3" SQUARE PATTERN. 12" PULLOUTS AND 2½" TWIN WHEEL CASTERS. UPS SHIPPABLE!!  
SIZE: 5'L X 21"W X 66"H FINISH: ALL CHROME



BLACK GRID DISPLAY



BLACK ROLLING RACK



DELUXE ROLLING RACKS

ONE-SIDED GRID DISPLAY RACK

CHROME

SPACE-SAVING, NESTABLE

#GR1X: ONE-SIDED GRID RACK ONE-SIDED DISPLAY UNIT WITH 4' X 4" GRID PANEL MOUNTED TO 1" SQUARE TUBULAR UPRIGHTS AND BASE: 2½" TWIN WHEEL CASTERS. WITH SNAP-TOGETHER DESIGN FOR EASY ASSEMBLY AND SHIPPING.  
SIZE: 4'L X 24"W X 64" FINISH: ALL CHROME

EASY SETUP, EASY TO SHIP

UPS SHIPPABLE



#GR1X

UPS-ABLE!



RECTANGULAR RACKS



WARDROBE RACKS



CLASSIC PIPE RACKS

nuease@aol.com | TEL: 201.723.8941 | FAX: 1-201-837-9427

NAVIGATE

NEXT>

<BACK

INDEX

ORDERING 1,2,3

HOW TO ORDER

PRICE LIST

ORDER FORM

E-MAIL ORDER

COMPLETE INDEX

CATALOG INDEX

DOWNLOAD PDF CATALOG

CONTACT US

SEND ORDER FORM AS EMAIL ATTACHMENT  
WE WILL PRINT & DELETE IMMEDIATELY

CALLED THE NEVER-SAG FOR ITS HEAVY 2" DIAMETER CAST TUBULAR BASES AND 1-1/4" HANGRAIL. THESE RACKS HAVE EVOLVED FROM A 50 YEAR OLD DESIGN THAT THE MOST EXCLUSIVE COUTURIERS AND FURRIERS HAVE PREFERRED FOR ITS ELEGENCE AND ABILITY TO WITHSTAND HEAVY USE.

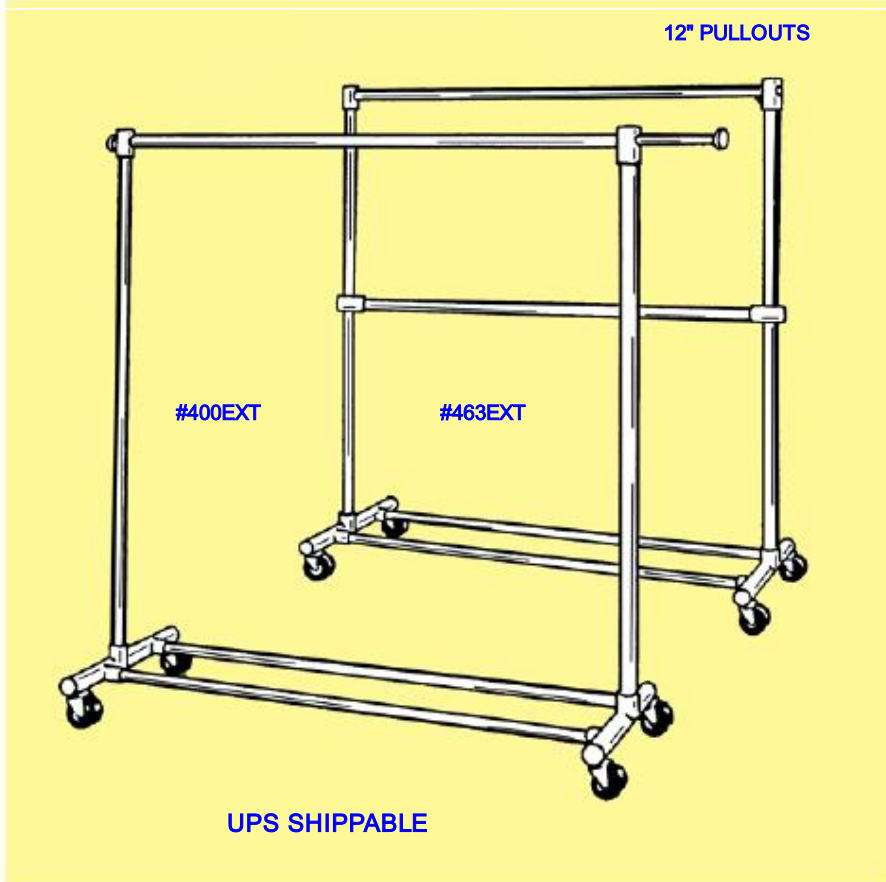

THE "NEVER-SAG" RACK

NOT TO BE CONFUSED WITH OUR #SWF OR #BWF RACKS AS SHOWN ON PG#11. THOSE ARE FOLDING RACKS FOR THE ROAD! THE #400EXT IS A SHOWROOM RACK, NOT COLLAPSIBLE.

#400EXT: DELUXE ROLLING RACK CONSTRUCTED OF HEAVY-DUTY 1 1/2" TRIPLE CHROME TUBING. END BASE SECTIONS ARE HEAVY 2" O.D. TUBING. HEAVY CAST FITTINGS LEND STABILITY WHILE 12" PULLOUT EXTENSIONS AND LARGE 4" EASY ROLLING CASTERS. THE MOST DESIRABLE SHOWROOM RACK. SIZE: 5'L X 66"H + 12" PULLOUTS

#400TALL: EXTRA-TALL DELUXE RACK SIZE: 5'L X 79"H + 12" PULLOUTS

#463EXT: TWO TIERED ROLLING RACK SAME AS THE #400EXT, BUT WITH A SECOND ADJ. HANGRAIL. ADDITIONAL HANGRAILS AVAILABLE. 79" HIGH



BLACK GRID DISPLAY



BLACK ROLLING RACK



DELUXE ROLLING RACKS



RECTANGULAR RACKS



WARDROBE RACKS



BUDGET COSTUMERS

RECTANGULAR ROLLING RACK TRIPLE-CHROME PLATED

MAGNIFICENTLY MODERN ROLLING RACK FOR THE CONTEMPORARY SHOWROOM. TASTEFUL AND DURABLE TO LAST FOR YEARS WITH GRACE AND STYLE.

RECTANGULAR BASE, UPRIGHTS

#386ADJ: RECTANGULAR ROLLING RACK DESIGNED FOR DURABILITY AND STYLE! CHROME PLATED TO A MIRROR FINISH. MADE OF 5/8" X 2" RECTANGULAR UPRIGHT FRAMES AND BOX BASE WITH AN 1 1/4" ROUND HANGRAIL BOX BASE LENDS RIGIDITY AND 2 1/2" TWIN WHEEL CASTERS ARE EASY ROLLING. RACK IS FULLY ADJUSTABLE 54" TO 76" SIZE: 5'L X 54-76" HIGH

ADJUSTABLE HEIGHT

UPS SHIPPABLE



nuease@aol.com | TEL: 201.723.8941 | FAX: 1-201-837-9427

- NAVIGATE
- NEXT>**
- <BACK**
- INDEX**

- ORDERING 1,2,3
- HOW TO ORDER
- PRICE LIST
- ORDER FORM
- E-MAIL ORDER

- COMPLETE INDEX
- CATALOG INDEX
- DOWNLOAD PDF CATALOG
- CONTACT US

SEND ORDER FORM AS EMAIL ATTACHMENT WE WILL PRINT & DELETE IMMEDIATELY

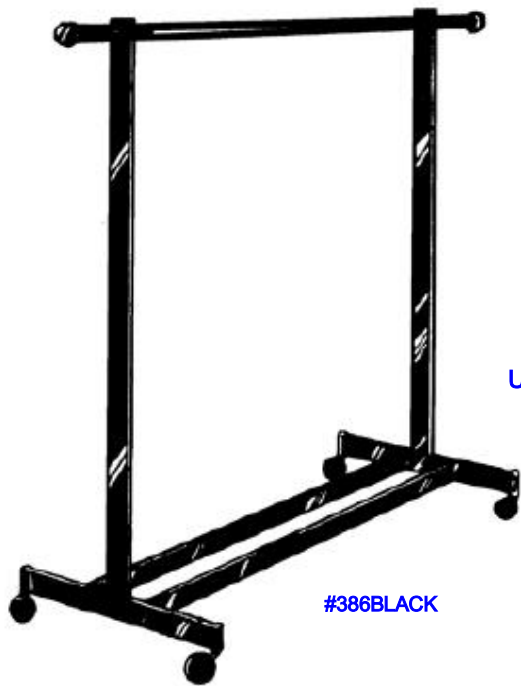

#386BLACK

BLACK SEMI-GLOSS

UPS SHIPPABLE



#GDC2X/5BLK

#386BLACK: RECTANGULAR ROLLING RACK [5'L X 64"H]  
BLACK EPOXY COATED SINGLE BAR ROLLING RACK  
MADE WITH A 5/8" X 2" RECTANGULAR TUBE BOX FRAME AND  
UPRIGHTS. HANGRAIL IS 1/4" ROUND TUBING.  
HAS 2 1/2" TWIN WHEEL BLACK HOODED CASTERS.

#GDC2X/5BLK: 'A' FRAME GRID RACK [5'L X 66"H]  
BLACK EPOXY COATED 'A' FRAME GRID DISPLAY RACK HAS 1"  
SQUARE TUBULAR FRAME AND 1/4" WIRE ROD GRID PANELS  
WITH 3" SQUARE OPENINGS. 2 1/2" BLACK TWIN WHEEL  
CASTERS, 12" CHROME PULLOUTS.



ROLLING GRID RACK



ROLLING LADDER RACK



DELUXE ROLLING RACKS

BLACK EPOXY FACE-OUT RACKS

ALL BLACK

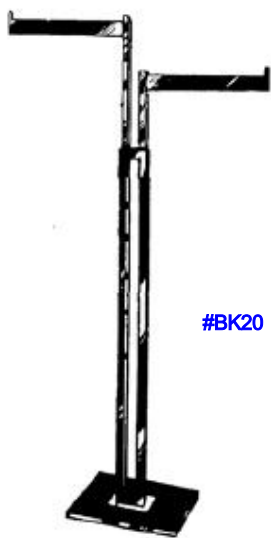

#BK20

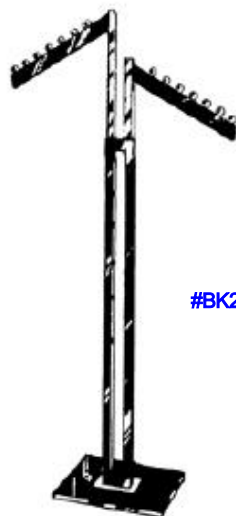

#BK25

BLACK SEMI-GLOSS

UPS-ABLE

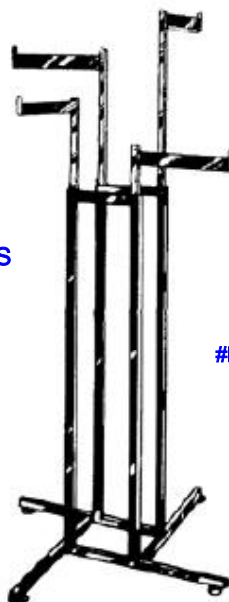

#BK10

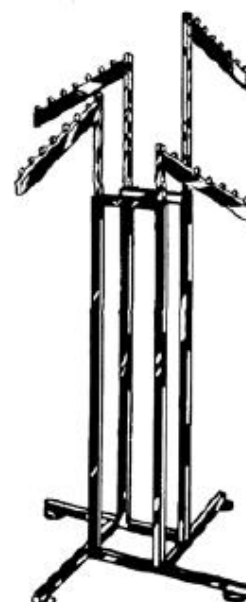

#BK15



RECTANGULAR RACKS



WARDROBE RACKS



BUDGET COSTUMERS

#BK20: TWO-WAY STRAIGHT ARM RACK [BLACK EPOXY]  
#BK25: TWO-WAY SLANT ARM RACK [BLACK EPOXY]  
EACH ARM IS INDEPENDENTLY ADJUSTABLE EVERY 3" FROM 48  
TO 72" HIGH. UPRIGHTS ARE 1" BLACK" SQUARE TUBING.  
HEAVY WEIGHTED BASE IS 12" X 15".

#BK10: FOUR-WAY STRAIGHT ARM RACK [BLACK EPOXY]  
#BK15: FOUR-WAY SLANT ARME RACK [BLACK EPOXY]  
EACH ARM IS INDEPENDENTLY ADJUSTABLE EVERY 3" FROM 48  
TO 72" HIGH. FRAME AND LEGS ARE 1" EPOXY COATED SQUARE  
TUBING. ADJ. LEVELERS INCLUDED.

nuease@aol.com | TEL: 201.723.8941 | FAX: 1-201-837-9427

NAVIGATE

NEXT >

< BACK

INDEX

ORDERING 1,2,3

HOW TO ORDER

PRICE LIST

ORDER FORM

E-MAIL ORDER

COMPLETE INDEX

CATALOG INDEX

DOWNLOAD PDF CATALOG

CONTACT US

SEND ORDER FORM AS EMAIL ATTACHMENT  
WE WILL PRINT & DELIVER IMMEDIATELY

HEAVY-DUTY NESTABLE ZEE RACKS



8.8 MIL  
CLEAR  
POLY

UPS-ABLE



#PT2464

#Z63: STOCKROOM RACK [62"L X 22"W X 66"H]  
1 1/4" O.D. TUBING AND Z-BASE DESIGN MAKE THESE PERFECT  
FOR STOCKROOM OR TRANSPORTATION. ZEE-FRAMES  
ALLOW NESTING FOR STORAGE. BLACK BASE, CHROME  
UPRIGHTS AND HANGRAIL. 4" CASTERS.  
#Z63/2T: TWO-TIERED RACK [62"L X 22"W X 78"H]

PT2464: COVER & SUPPORT BARS [63.5"W x 69.5"H x 2.5"D]  
ZIPPERED RACK COVER FITS OVER OUR #Z63 Z-RACK. INCLUDES  
TWO SUPPORT BARS AND GARMENT COVER. CENTER ZIPPER  
ALLOWS EASY RETRIEVAL OF GARMENTS. PROVIDES  
DIRT-RESISTANCE WITHOUT HIDING GARMENTS.

WARDROBE SUPPLY



WARDROBE SUPPLY



CLASSIC PIPE RACKS



CROSSOVER RACKS



ALTA WALL UNIT

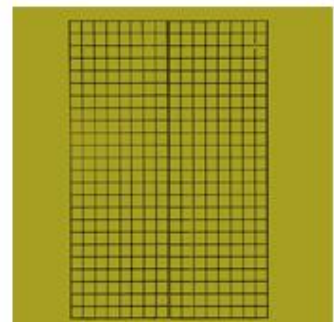

GRID WALL DISPLAY



LADDER WALL UNITS

VERSATILE STORE RACKS

SATIN CHROME



DOUBLE  
ADJUSTABLE  
HANGRAILS

#BB/48

UPS-ABLE



A FOLDING  
ROLLING RACK  
WITH TANDEM  
HANGRAILS

#DWF-2X

DOUBLE FOLDING RACK

#BB/48: DOUBLE ADJUSTABLE HANGRAIL RACK  
SATIN CHROME TWO-SIDED RACK WITH INDIVIDUALLY  
ADJUSTABLE HANGRAILS ON EACH SIDE.  
AVAILABLE WITH 2" TWIN WHEEL CASTERS  
SIZE: [48L X 24 X 49-73"H]

#DWF-2X: DOUBLE FOLDING RACK [48 X 30 X 54-64"]  
16 GA. ROUND TUBING, HELI-ARC STEEL WELDED FOR  
SUPERIOR STRENGTH, END BASE SECTIONS REINFORCED  
WITH SOLID STEEL BARS AND SATIN CHROME PLATED. HAS  
TWO 48" HANGRAILS, ADJUSTABLE TO 64".

nuease@aol.com | TEL: 201.723.8941 | FAX: 1-201-837-9427

NAVIGATE

NEXT >

< BACK

INDEX

ORDERING 1,2,3

HOW TO ORDER

PRICE LIST

ORDER FORM

E-MAIL ORDER

COMPLETE INDEX

CATALOG INDEX

DOWNLOAD PDF CATALOG

CONTACT US

SEND ORDER FORM AS EMAIL ATTACHMENT  
WE WILL PRINT & DELETE IMMEDIATELY

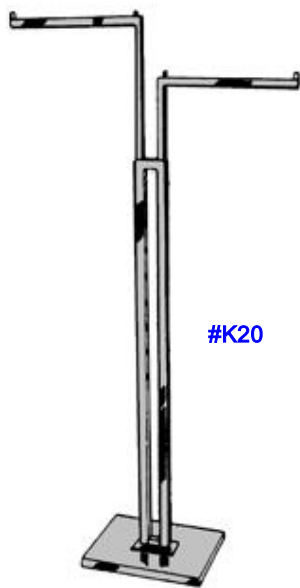

#K20

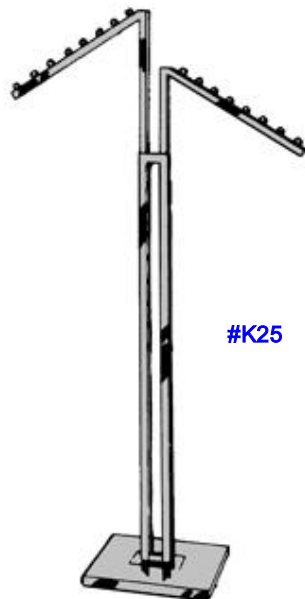

#K25

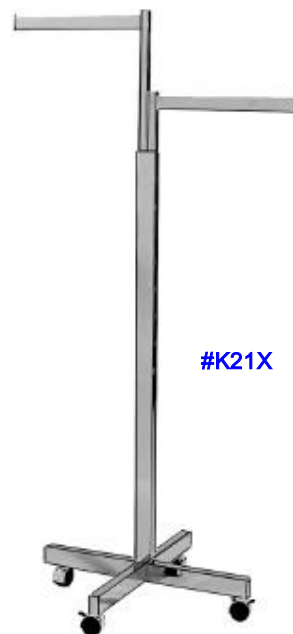

#K21X

UPS-ABLE

#K20: TWO STRAIGHT ARMS HEAVY 16 GA. SQUARE TUBING, CHROME PLATED, WITH AN 18 LB. SQUARE BASE. ARMS ARE 16" LONG ADJUSTABLE FROM 48 TO 72" HIGH.

#K25: TWO SLANT ARMS HEAVY 16 GA. SQUARE TUBING, CHROME PLATED, WITH AN 18 LB. SQUARE BASE. 8 BALL ARMS ARE 16" LONG. ADJUSTABLE : 48 TO 72"

#K21X: X-BASE TWO STRAIGHT ARM TWO 16" ADJ. STRAIGHT ARMS IN A 1" X 2" RECTANGULAR UPRIGHT ON AN "X-STYLE" BASE WITH TWIN WHEEL CASTERS. 48" TO 72" HIGH.

RELATED ITEMS



WARDROBE SUPPLY



CLASSIC PIPE RACKS



ALTA WALL UNIT

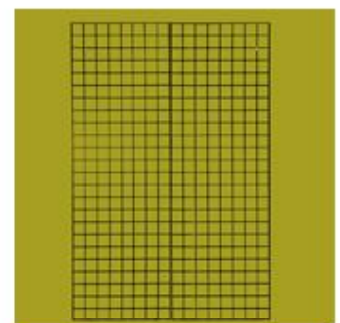

GRID WALL DISPLAY



LADDER WALL UNITS



ROLLING LADDER WALL

FOUR-WAY AND SPIRAL RACKS

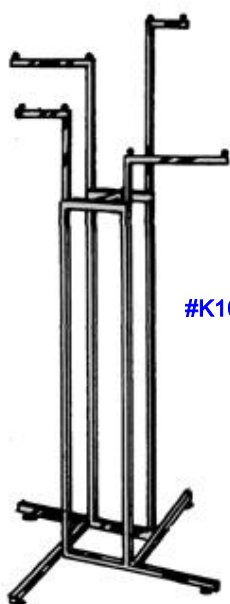

#K10

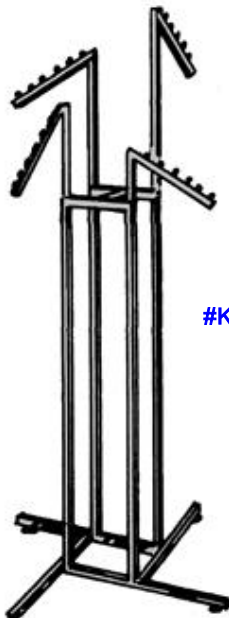

#K15



#K29

UPS-ABLE

#K10: FOUR STRAIGHT ARMS MADE OF HEAVY 16 GA. SQUARE TUBING, CHROME PLATED. 16" LONG ARMS ARE ADJUSTABLE: 48 TO 72"

#K15: FOUR SLANT ARMS MADE OF HEAVY 16 GA. SQUARE TUBING, CHROME PLATED. 16" LONG 8 BALL SLANT ARMS ARE ADJUSTABLE: 48 TO 72" H

#K29: SPIRAL RACK 29 BALL HANGRAIL MOUNTED ON A 67" HIGH UPRIGHT. 18" ROUND CAST BASE. UPRIGHT THREADED FOR SIGN STEM. BASE 18 LBS

nuease@aol.com | TEL: 201.723.8941 | FAX: 1-201-837-9427

NAVIGATE

NEXT >

< BACK

INDEX

ORDERING 1,2,3

HOW TO ORDER

PRICE LIST

ORDER FORM

E-MAIL ORDER

COMPLETE INDEX

CATALOG INDEX

DOWNLOAD PDF CATALOG

CONTACT US

SEND ORDER FORM AS EMAIL ATTACHMENT WE WILL PRINT & DELETE IMMEDIATELY



BEAUTIFUL PIPE RACKS IN CHARCOAL OR EPOXY WHITE FINISH. A RETRO LOOK THAT RECALLS THE "GARMENT CENTER'S" HISTORY. MOST UNITS ARE HEIGHT ADJUSTABLE AND COME WITH EASY ROLLING CASTERS. BOTH ATTRACTIVE AND ECONOMICAL. LET PAST AND PRESENT MEET IN A WELL-CONCEIVED SHOWROOM DISPLAY.



UPS-ABLE

#TR4B-adj: single bar - grey  
 #TR4W-adj: single bar - white  
 44" X 24" X 48-72" ADJUSTABLE PIPE RACK. WITH 3" CASTERS. GREY OR WHITE EPOXY FINISH

#TR5B-adj: single bar - grey  
 #TR5W-adj: single bar - white  
 5' X 24" X 48-72" ADJUSTABLE PIPE RACK. WITH 3" CASTERS. GREY OR WHITE EPOXY FINISH

#TR4B-ctr/adj: double bar - grey  
 #TR4W-ctr/adj: double bar - white  
 44" X 24" X 48-72" ADJUSTABLE PIPE RACK. HAS ADJ. CENTER HANGRAIL AND 3" CASTERS. GREY OR WHITE EPOXY FINISH

CTR/TR4B: center hangrail [only]  
 CTR/TR4W: center hangrail [only]



WARDROBE SUPPLY



ALTA WALL UNIT

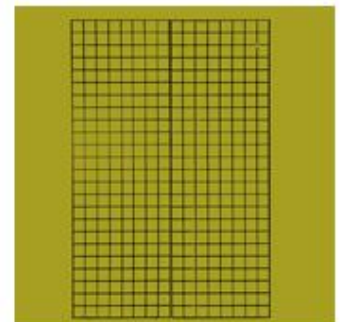

GRID WALL DISPLAY



LADDER WALL UNITS



ROLLING LADDER WALL



EURO WALL SYSTEM

PIPE RACK COSTUMERS

DARK GREY - WHITE

UPS-ABLE

#TR1XB: single costumer - grey  
 #TR1XW: single costumer - white  
 21" X 21" X 60" COSTUMER. WITH 3" CASTERS. GREY OR WHITE EPOXY FINISH

#TR2XB-adj: two-way rack - grey  
 #TR2XW-adj: two-way rack - white  
 21" X 21" X 44 -72" ADJUSTABLE RACK WITH 13" FACE-OUTS AND EASY ROLLING 3" CASTERS. GREY OR WHITE EPOXY FINISH

#TR4XB-adj: four-way rack - grey  
 #TR4XW-adj: four-way rack - white  
 21" X 21" X 44 -72" ADJUSTABLE RACK WITH 16" LONG ARMS. WITH 3" CASTERS. GREY OR WHITE EPOXY FINISH



[neuse@aol.com](mailto:neuse@aol.com) | TEL: 201.723.8941 | FAX: 1-201-837-9427

NAVIGATE

- [NEXT >](#)
- [< BACK](#)
- [INDEX](#)

ORDERING 1,2,3

- [HOW TO ORDER](#)
- [PRICE LIST](#)
- [ORDER FORM](#)
- [E-MAIL ORDER](#)

COMPLETE INDEX

- [CATALOG INDEX](#)
- [DOWNLOAD PDF CATALOG](#)
- [CONTACT US](#)

SEND ORDER FORM AS EMAIL ATTACHMENT  
 WE WILL PRINT & DELETE IMMEDIATELY

SHOW A MIX OF MERCHANDISE FOLDED OR HANGING. ALL UNITS ARE WITH TUBULAR FRAMES, BRACKETS, SHELVES, HANGRAILS AND TWIN-WHEEL CASTERS.



#K410/B

MATTE BLACK

#K410/B: BLACK FRAME/  
BLACK SHELVES FOUR SHELF  
CAPACITY WITH TWO  
FACE-OUTS. MADE  
OF 1" SQUARE TUBING WITH  
MATTE BLACK FINISH

#K400/B: BLACK FRAME/  
BLACK SHELVES FOUR SHELF  
CAPACITY WITH TWO 16"  
FACE-OUTS.  
MADE OF 1" X 2"  
RECTANGULAR TUBING WITH  
MATTE BLACK FINISH

UPS-ABLE



#K400/B



ALTA WALL UNIT

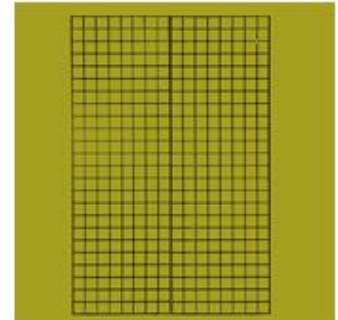

GRID WALL DISPLAY



LADDER WALL UNITS



ROLLING LADDER WALL



EURO WALL SYSTEM

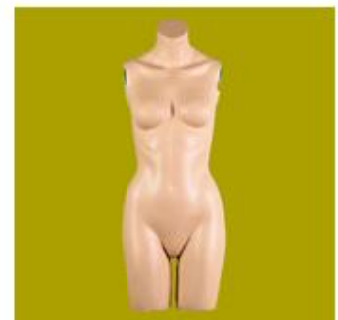

SYSTEM MANNEQUINS

CROSS MERCHANDISERS / 8 SHELF UNITS

BLACK



#K411/B

MATTE BLACK

UPS  
SHIPABLE

#K411/B: BLACK FRAME/ BLACK SHELVES  
DOUBLE HANGRAIL BOX RACK WITH EIGHT  
SHELVES. 1" SQUARE TUBING IN MATTE BLACK.



#K402/B

#K402/B: BLACK FRAME/ BLACK SHELVES  
EIGHT SHELVES ADJ. DISPLAY UPRIGHT. 1" X 2"  
RECTANGULAR TUBING IN MATTE BLACK FINISH.

nuease@aol.com | TEL: 201.723.8941 | FAX: 1-201-837-9427

NAVIGATE

NEXT >

< BACK

INDEX

ORDERING 1,2,3

HOW TO ORDER

PRICE LIST

ORDER FORM

E-MAIL ORDER

COMPLETE INDEX

CATALOG INDEX

DOWNLOAD PDF CATALOG

CONTACT US

SEND ORDER FORM AS EMAIL ATTACHMENT  
WE WILL PRINT & DELETE IMMEDIATELY

HIDDEN WALL MOUNTS



#T500SC

#T500SC: WALL MODULE [96 X 50 X 16"] STREAMLINED PERIMETER MERCHANDISING UNIT. UNIVERSAL, REAR DOUBLE-SLOTTED UPRIGHTS [1/2" SLOTS ON 1" CENTERS]. ACCEPTS REAR MOUNTED 48 X 12" SHELVES AND 48"L HANGRAILS.

RECTILINEAR STEEL GIVES THE "ALTA" SYSTEM A MODERN, STRUCTURAL LOOK. SATIN CHROME FINISH, MAPLE SHELVES AND TOPS, MAKE AN ELEGANT APPEARANCE. WALL MODULES USE HIDDEN WALL MOUNTS FOR A SLEEK LOOK. "ALTA" IS AN EFFICIENT WAY TO DISPLAY MERCHANDISE AND YOU CAN USE STANDARD HARDWARE THROUGHOUT.



RELATED ITEMS

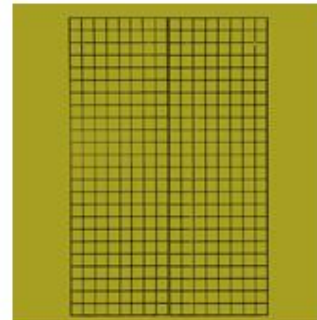

GRID WALL DISPLAY



LADDER WALL UNITS



ROLLING LADDER WALL



EURO WALL SYSTEM



SYSTEM MANNEQUINS



BENDABLE MANNEQUINS

"ALTA" MERCHANDISERS

SATIN CHROME



#T502SC

#T502SC: CROSS MDSG 4-WAY RACK [4] DISPLAY ARMS AND [8] OPTIONAL SHELVES. BUILT-IN SIGN FRAME. [4] 16" RECT. ARMS, ADJ. 45-72"H. 2" SQUARE FRAME WITH 1/2" SLOTS.



#T503SC

#T503SC-H: 2-SIDED ISLAND MULTI-MERCHANDISER WITH SHELVES AND HANGRAILS. TOP SHELF FOR DISPLAYS. 2" SQUARE TUBING WITH 1/2" SLOTS.



#TSF481H: 13X48X3/4"  
#TSF121H: 11 1/2X12X3/4"  
MAPLE MELAMINE SHELVES

#GHSL12-SC  
#GHSR12-SC



#RE4-SC



#CR3-SC

#CR12-SC



#RH5H-SC

#RH12-SC



nuease@aol.com | TEL: 201.723.8941 | FAX: 1-201-837-9427

NAVIGATE

NEXT >

< BACK

INDEX

ORDERING 1,2,3

HOW TO ORDER

PRICE LIST

ORDER FORM

E-MAIL ORDER

COMPLETE INDEX

CATALOG INDEX

DOWNLOAD PDF CATALOG

CONTACT US

SEND ORDER FORM AS EMAIL ATTACHMENT  
WE WILL PRINT & DELIVER IMMEDIATELY

GRID WALL PANELS FOR WALL MOUNTING OR FREE STANDING UNITS. CREATE A SHOWROOM WITHIN A SHOWROOM, OR USE AS A DISPLAY BOOTH AT TRADE SHOWS. THE POSSIBILITIES ARE INFINITE!

GRID PANELS ARE MADE OF 1/4" WIRE ROD IN A 3 X 3" SQUARE PATTERN WITH ALL JOINING POINTS WELDED, GROUND AND POLISHED. VERTICAL SIDES HAVE A DOUBLE-WIRE EDGE FOR STRENGTH. USE WALL BRACKETS FOR MOUNTING OR JOINER CLIPS TO CREATE FREE-STANDING DISPLAYS.

HIGH QUALITY GRIDWALL

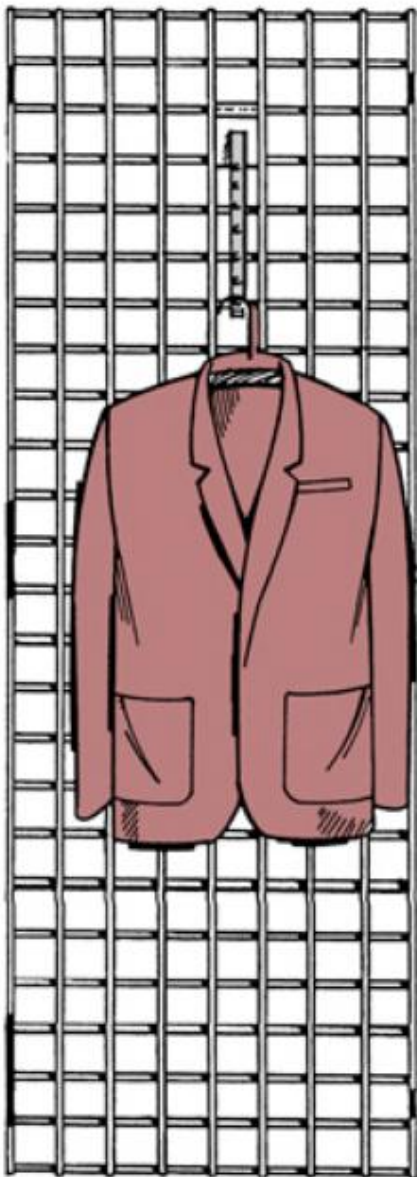

- |        |   |
|--------|---|
| CHROME | BLACK—SIZE                              |
| #WG4   | #BWG4—2' X 4'— [UPS-able: 3/ per box]   |
| #WG5   | #BWG5—2' X 5'— [UPS-able: 3/ per box]   |
| #WG6   | #BWG6—2' X 6'— [UPS-able: 3/ per box]   |
| #WG7   | #BWG7—2' X 7'— [TRUCK: 12/ pc minimum]  |
| #WG8   | #BWG8—2' X 8'— [TRUCK: 12/ pc minimum]  |
| #WG44  | #BWG44—4' X 4'— [TRUCK: 12/ pc minimum] |

WALL MOUNT BRACKET

- #WC1: CHROME  
#BWC1: BLACK



JOINER CLIP

- #JC1: CHROME  
#BJC1: BLACK



GRID HOOKS

FULL BOXES  
BOX=96 PCS.

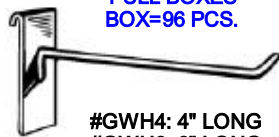

- CHROME  
BLACK

- #GWH4: 4" LONG  
#GWH6: 6" LONG  
#GWH8: 8" LONG  
#GWH10: 10" LONG



- CHROME  
FITS 1-1/4  
TUBE

GRID LEGS



- #GL24/C CHROME  
#GL24/B BLACK

WALL HUGGERS



TWIN WHEEL  
CASTERS  
AVAILABLE!

FULL BOXES  
ONLY!  
12 PCS.



"L" SHAPED  
LEGS ARE FOR  
USE AGAINST  
WALLS

- #GL512/C CHROME  
#GL512/B BLACK

QUAD GRID BASE



- #GW4X/C CHROME  
#GW4X/B BLACK

TRI GRID BASE

INCLUDES  
TWIN WHEELS



- #GW3X/C CHROME  
#GW3X/B BLACK

**\*\* CONSUMER ALERT \*\***

DO NOT BE MISLED BY COMPETITOR'S POOR QUALITY GRIDS! MANY USE A LIGHTER METRIC GAUGE WIRE MAKING PANELS EASILY BENT OR WARPED. OUR GRID IS 1/4" WIRE ROD, HAS REINFORCED DOUBLE-WIRE EDGES, IS WELDED AT ALL CROSS POINTS. A WEIGH BOTH GRIDS AND IT WILL SHOW OUR GRID TO BE TWO POUNDS HEAVIER AND STRONGER!



LADDER WALL UNITS



ROLLING LADDER WALL



EURO WALL SYSTEM



SYSTEM MANNEQUINS



BENDABLE MANNEQUINS



JERSEY FORMS

nuease@aol.com | TEL: 201.723.8941 | FAX: 1-201-837-9427

NAVIGATE

NEXT>

<BACK

INDEX

ORDERING 1,2,3

HOW TO ORDER

PRICE LIST

ORDER FORM

E-MAIL ORDER

COMPLETE INDEX

CATALOG INDEX

DOWNLOAD PDF CATALOG

CONTACT US

SEND ORDER FORM AS EMAIL ATTACHMENT  
WE WILL PRINT & DELETE IMMEDIATELY

GRIDWALL FACE-OUTS

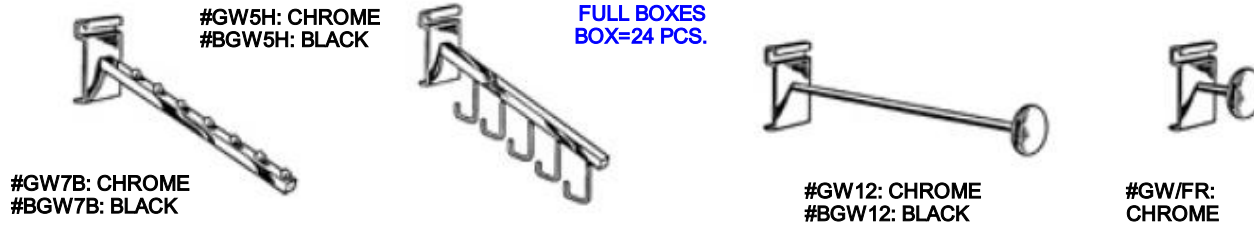

GRIDWALL BRACKETS

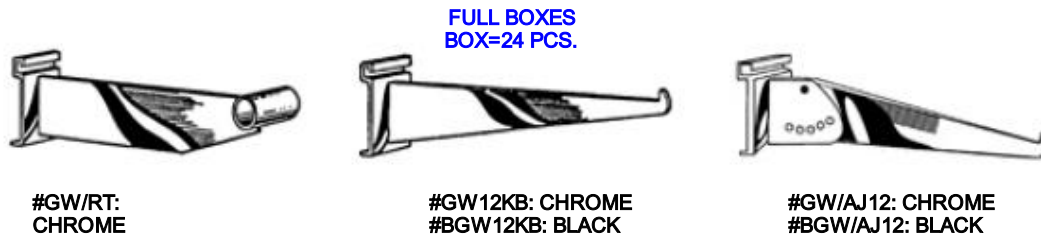

GRIDWALL SHELVES

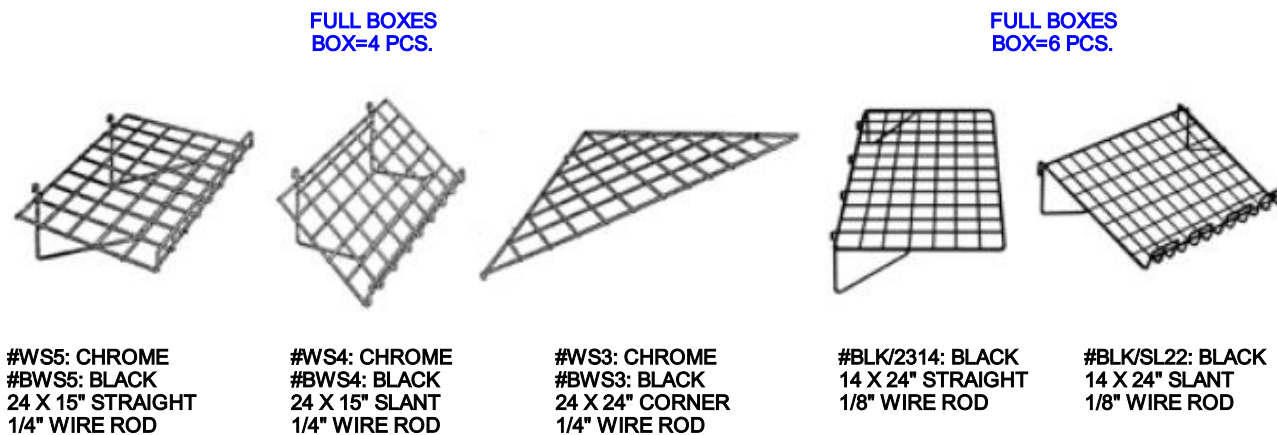

GRID SHELVES AND HANGRAILS

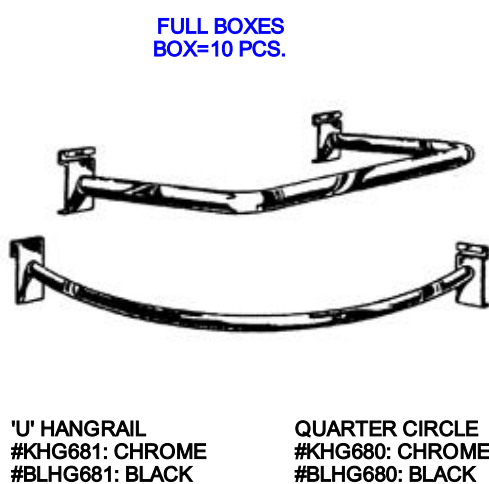

#DCS424: 15 X 24"  
#DCS436: 15 X 36"  
#DCS448: 15 X 48"  
4 PER BOX  
INDICATE FINISH:  
BLACK [B]  
WHITE [W]

#PW/1224---12 X 24"  
8 PER BOX  
#PW/1248---12 X 48"  
#PW/1448---14 X 48"  
4 PER BOX  
INDICATE FINISH:  
BK = BLACK  
WH = WHITE  
MP = MAPLE

BULLNOSE DURON WITH SOLID BACK



DURABLE 3/4" MELAMINE SHELVES



LADDER WALL UNITS



ROLLING LADDER WALL



EURO WALL SYSTEM



SYSTEM MANNEQUINS



BENDABLE MANNEQUINS



JERSEY FORMS

nuease@aol.com | TEL: 201.723.8941 | FAX: 1-201-837-9427

NAVIGATE



ORDERING 1,2,3



COMPLETE INDEX



SEND ORDER FORM AS EMAIL ATTACHMENT  
WE WILL PRINT & DELETE IMMEDIATELY

THE VERSATILE "LADDER SYSTEM" ALLOWS THE VARIANCE OF YOUR MERCHANDISING TECHNIQUE TO SUIT ANY DEPARTMENT OR LOCATION'S NEEDS, UTILIZING HANGRAILS, FACE-OUTS OR SHELVES. GREAT FOR RETAILERS, BUT HANDY FOR SHOWROOMS AND TRADE SHOWS BECAUSE OF THE EASY SETUPS AND MODULAR CAPABILITIES.

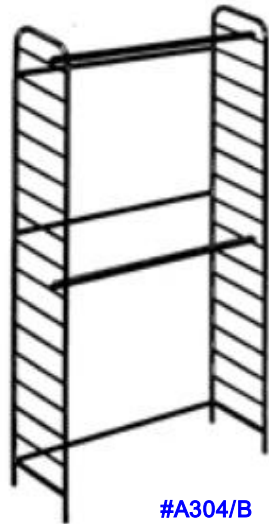

#A304/B

SINGLE WALL UNIT: 16 X 48 X 88" HIGH  
[2] EPOXY HANGRAILS WITH PROTECTIVE 1/4" CHROME WIRE ON TOP. 5/16" LEVELERS.  
#A304/B: BLACK EPOXY

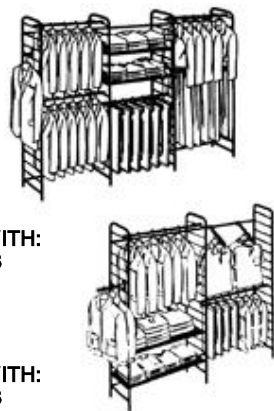

SHOWN WITH:  
[2]-#A304/B  
#ARL48/B  
#AT77/B  
#AF3/B

SHOWN WITH:  
[1]-#A305/B  
#AF8/B  
#AF12/B

SHIPS BY TRUCK



#A305/B

DOUBLE WALL UNIT: 16 X 96 X 88" HIGH  
[4] EPOXY HANGRAILS WITH PROTECTIVE 1/4" CHROME WIRE ON TOP. 5/16" LEVELERS.  
#A305/B: BLACK EPOXY



ROLLING LADDER WALL



EURO WALL SYSTEM



SYSTEM MANNEQUINS

LADDER TOWER AND ACCESSORIES

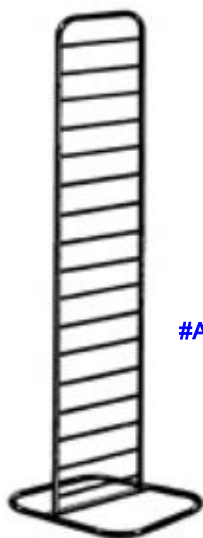

#A306/B

LADDER TOWER UNIT:  
14 X 73" HIGH WITH  
18 X 22" TUBULAR BASE  
#A306/B: BLACK EPOXY

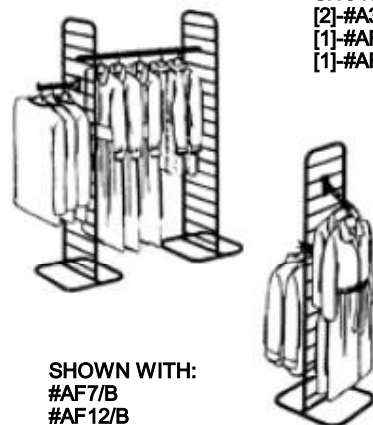

SHOWN WITH:  
#AF7/B  
#AF12/B

SHOWN WITH:  
[2]-#A306/B  
[1]-#ARL48/B  
[1]-#AF12/B



#AF3/B

#AF12/B

#AF7/B

#ARL48/B



#ARL48/B: 48" HANGRAIL WITH PROTECTIVE 1/4" CHROME WIRE ROD

#AT77/B



INTERIOR SHELF: 14 X 45"  
[FITS A304, A305 & A306]  
#AT77/B: BLACK

SHIPS BY UPS



BENDABLE MANNEQUINS



JERSEY FORMS

nuease@aol.com | TEL: 201.723.8941 | FAX: 1-201-837-9427

NAVIGATE

NEXT >

< BACK

INDEX

ORDERING 1,2,3

HOW TO ORDER

PRICE LIST

ORDER FORM

E-MAIL ORDER

COMPLETE INDEX

CATALOG INDEX

DOWNLOAD PDF CATALOG

CONTACT US

SEND ORDER FORM AS EMAIL ATTACHMENT  
WE WILL PRINT & DELIVER IMMEDIATELY



FLEXIBLE JERSEY FORMS

THE NEW LINEA COLLECTION ALLOWS FLEXIBILITY FOR BOTH SHOWROOMS AND STORES. THE HANDSOME BRONZE FINISH AND HANGRAILS AND SHELVES OFFER UNLIMITED POSSIBILITIES.



EURO WALL SYSTEM



SYSTEM MANNEQUINS



BENDABLE MANNEQUINS



JERSEY FORMS



FLEXIBLE JERSEY FORMS



SEXY MANNEQUINS

LINEA UNITS

BRONZE



LNBBE

Our exciting, upscale Linea Collection has been expanded to include our sleek new Adjustable Height Extended Ballet Bar. made from 1" square tubing and inished with a refined Statuary Bronze epoxy coating. The height adjusts from 45" to 72" in 3" increments. CASTERS



LNSWBEE

The Extended Ballet Bar With Swivel Hang Bars offer multiple built-in display options. The swivel hang bars provide the ideal solution to display high-end designer collections.



INHFET

An Etagere that can tum an underutilized selling floor corner into a money-maker. Constructed from 1" square tubing, includes four 16" W x 16" L x 3/16" D glass shelves.

[nuease@aol.com](mailto:nuease@aol.com) | TEL: 201.723.8941 | FAX: 1-201-837-9427

NAVIGATE

[NEXT >](#)

[< BACK](#)

[INDEX](#)

ORDERING 1,2,3

[HOW TO ORDER](#)

[PRICE LIST](#)

[ORDER FORM](#)

[E-MAIL ORDER](#)

COMPLETE INDEX

[CATALOG INDEX](#)

[DOWNLOAD PDF CATALOG](#)

[CONTACT US](#)

SEND ORDER FORM AS EMAIL ATTACHMENT  
WE WILL PRINT & DELETE IMMEDIATELY

THE EURO SYSTEM IS IN A EUROPEAN STYLE! IF YOU'RE TIRED OF BLACK, WHITE & CHROME IS THE NEW LOOK! ALL FLOOR UNITS ARE AVAILABLE WITH WHEELS, INCLUDING A UNIQUE 'A' FRAME ROLLING RACK, SUITABLE FOR SHOWROOMS OR STORES.

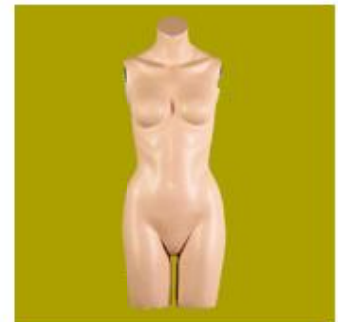

SYSTEM MANNEQUINS



BENDABLE MANNEQUINS



JERSEY FORMS



FLEXIBLE JERSEY FORMS



SEXY MANNEQUINS

"EURO" COMPONENTS

GLOSS WHITE / CHROME



A - FRAME RACK [WHEELS OPTIONAL]  
 ELD-AF: 56"L X 20"W X 56"H  
 FRAME = 1.25" SQUARE TUBING  
 HANGRAIL = 1.25" ROUND TUBING



#TW25

2-WAY & 4-WAY COSTUMERS  
 ELD-T: HEIGHT ADJ = 44 - 59" / ARM = 14" LONG  
 ELD-4: HEIGHT ADJ = 55 - 70" / ARM = 16" LONG  
 [WHEELS OPTIONAL]

nuease@aol.com | TEL: 201.723.8941 | FAX: 1-201-837-9427

NAVIGATE

- [NEXT >](#)
- [< BACK](#)
- [INDEX](#)

ORDERING 1,2,3

- [HOW TO ORDER](#)
- [PRICE LIST](#)
- [ORDER FORM](#)
- [E-MAIL ORDER](#)

COMPLETE INDEX

- [CATALOG INDEX](#)
- [DOWNLOAD PDF CATALOG](#)
- [CONTACT US](#)

SEND ORDER FORM AS EMAIL ATTACHMENT  
 WE WILL PRINT & DELETE IMMEDIATELY

WARDROBE SUPPLY



WARDROBE SUPPLY



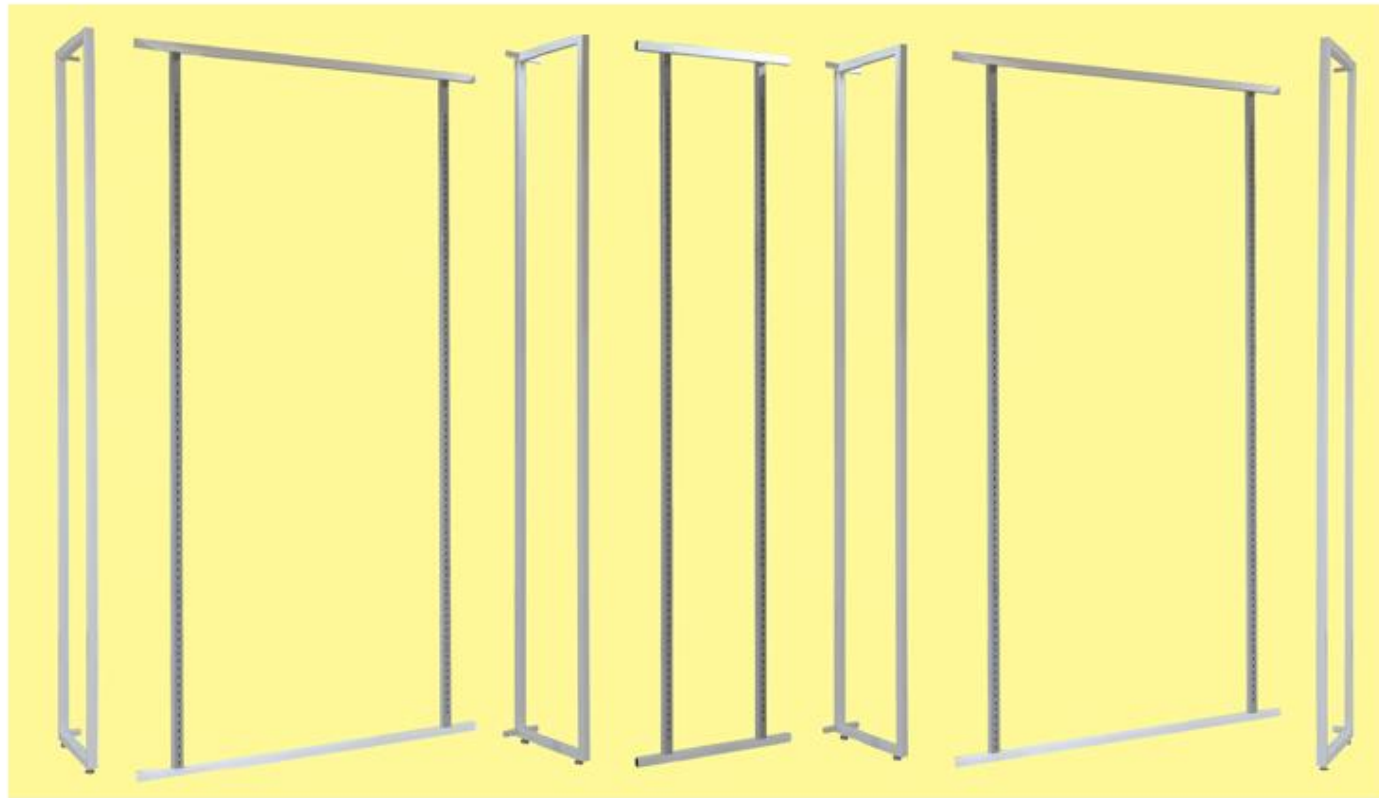

ELD-A [LEFT] LEFT END CAP    ELD-B SLOTTED FRAME    ELD-D CONNECTOR    ELD-C ADD-ON    ELD-D    ELD-B    ELD-A [RIGHT] LEFT END CAP

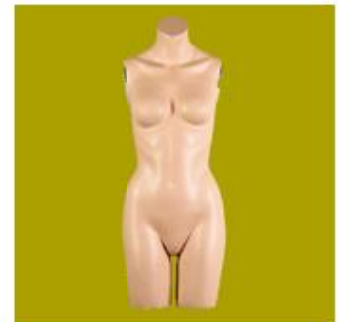

SYSTEM MANNEQUINS



BENDABLE MANNEQUINS



JERSEY FORMS



FLEXIBLE JERSEY FORMS

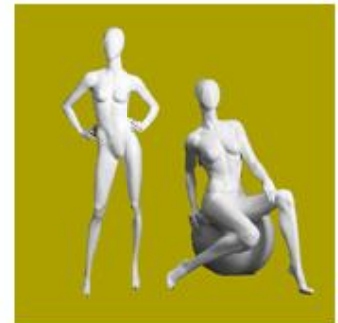

SEXY MANNEQUINS

"EURO" COMPONENTS

GLOSS WHITE / CHROME



SETUP# 1 [4'-4"]  
ELD-A LEFT, ELD-A RIGHT  
ELD-B



SETUP# 2 [6'-7"]  
ELD-A LEFT, ELD-A RIGHT  
ELD-B, ELD-D, ELD-C

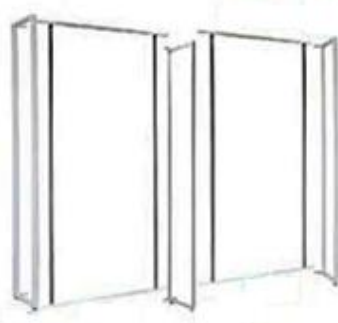

SETUP# 3 [8'-7"]  
ELD-A LEFT, ELD-A RIGHT  
ELD-B, ELD-B, ELD-D



SETUP# 4 [10'-10"]  
ELD-A LEFT, ELD-A RIGHT  
ELD-B, ELD-B, ELD-C, ELD-D, ELD-D,



#CR3 = 3" LONG  
#CR12 = 12" L



#RE2 = 2' L  
#RE4 = 4' L

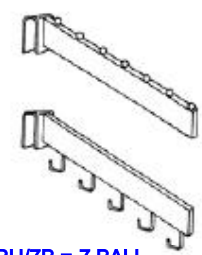

#RH/7B = 7 BALL  
#RH/5H = 5 HOOK

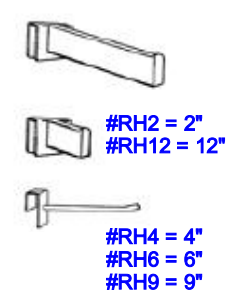

#RH2 = 2"  
#RH12 = 12"  
#RH4 = 4"  
#RH6 = 6"  
#RH9 = 9"



#7B/TS = 7 BALL  
#5H/TS = 5 HOOK  
#12/TS = 12" ARM



#GB12 = 12" L



3/4" MELAMINE WOOD SHELF  
WS1224-W = 12" X 24" WHITE  
WS1248-W = 12" X 48" WHITE  
WS1448-W = 14" X 48" WHITE

nuease@aol.com | TEL: 201.723.8941 | FAX: 1-201-837-9427

NAVIGATE

NEXT >

< BACK

INDEX

ORDERING 1,2,3

HOW TO ORDER

PRICE LIST

ORDER FORM

E-MAIL ORDER

COMPLETE INDEX

CATALOG INDEX

DOWNLOAD PDF CATALOG

CONTACT US

SEND ORDER FORM AS EMAIL ATTACHMENT  
WE WILL PRINT & DELETE IMMEDIATELY

WARDROBE SUPPLY



WARDROBE SUPPLY

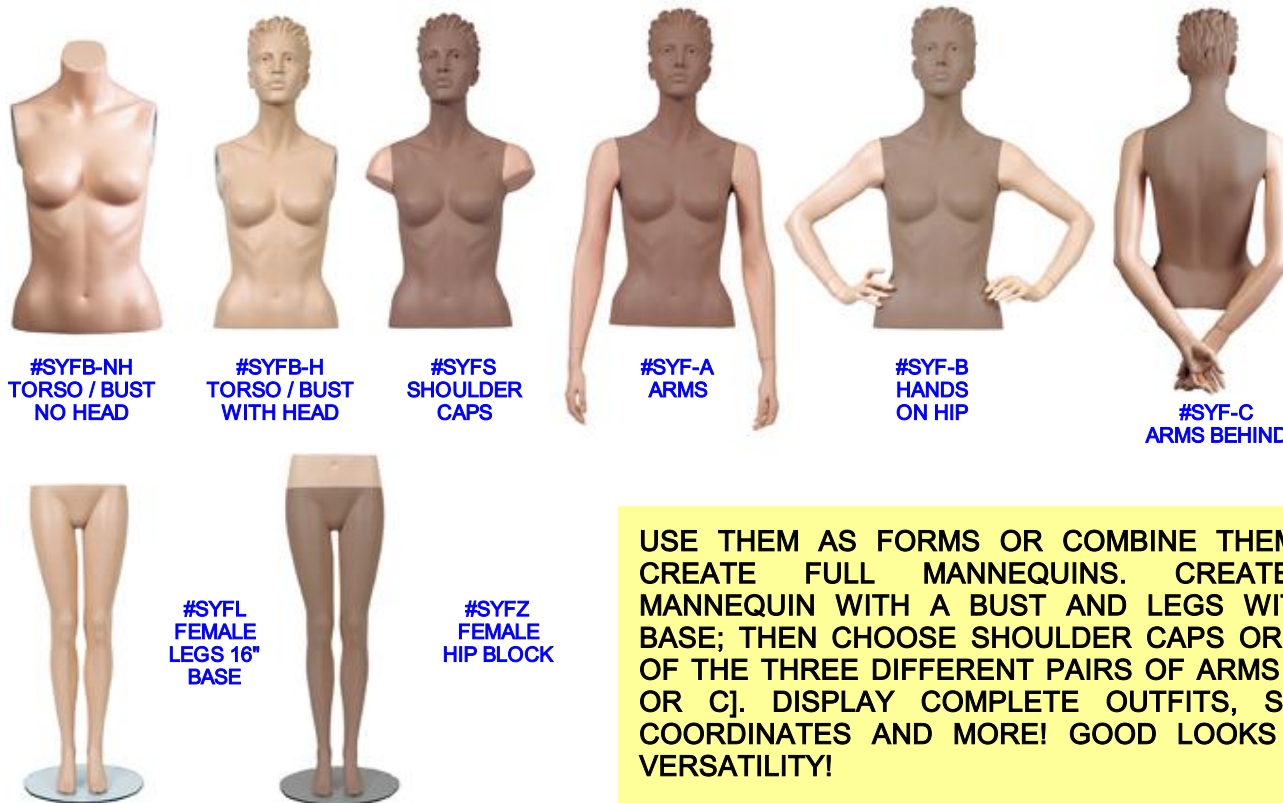

#SYFB-NH  
TORSO / BUST  
NO HEAD

#SYFB-H  
TORSO / BUST  
WITH HEAD

#SYFS  
SHOULDER  
CAPS

#SYF-A  
ARMS

#SYF-B  
HANDS  
ON HIP

#SYF-C  
ARMS BEHIND

#SYFL  
FEMALE  
LEGS 16"  
BASE

#SYFZ  
FEMALE  
HIP BLOCK

USE THEM AS FORMS OR COMBINE THEM TO CREATE FULL MANNEQUINS. CREATE A MANNEQUIN WITH A BUST AND LEGS WITH A BASE; THEN CHOOSE SHOULDER CAPS OR ONE OF THE THREE DIFFERENT PAIRS OF ARMS [A, B OR C]. DISPLAY COMPLETE OUTFITS, SUITS, COORDINATES AND MORE! GOOD LOOKS AND VERSATILITY!

RELATED ITEMS



HANGING BODYFORMS



BENDABLE MANNEQUINS



JERSEY FORMS



FLEXIBLE JERSEY FORMS



SEXY MANNEQUINS

MALE SYSTEM MANNEQUINS

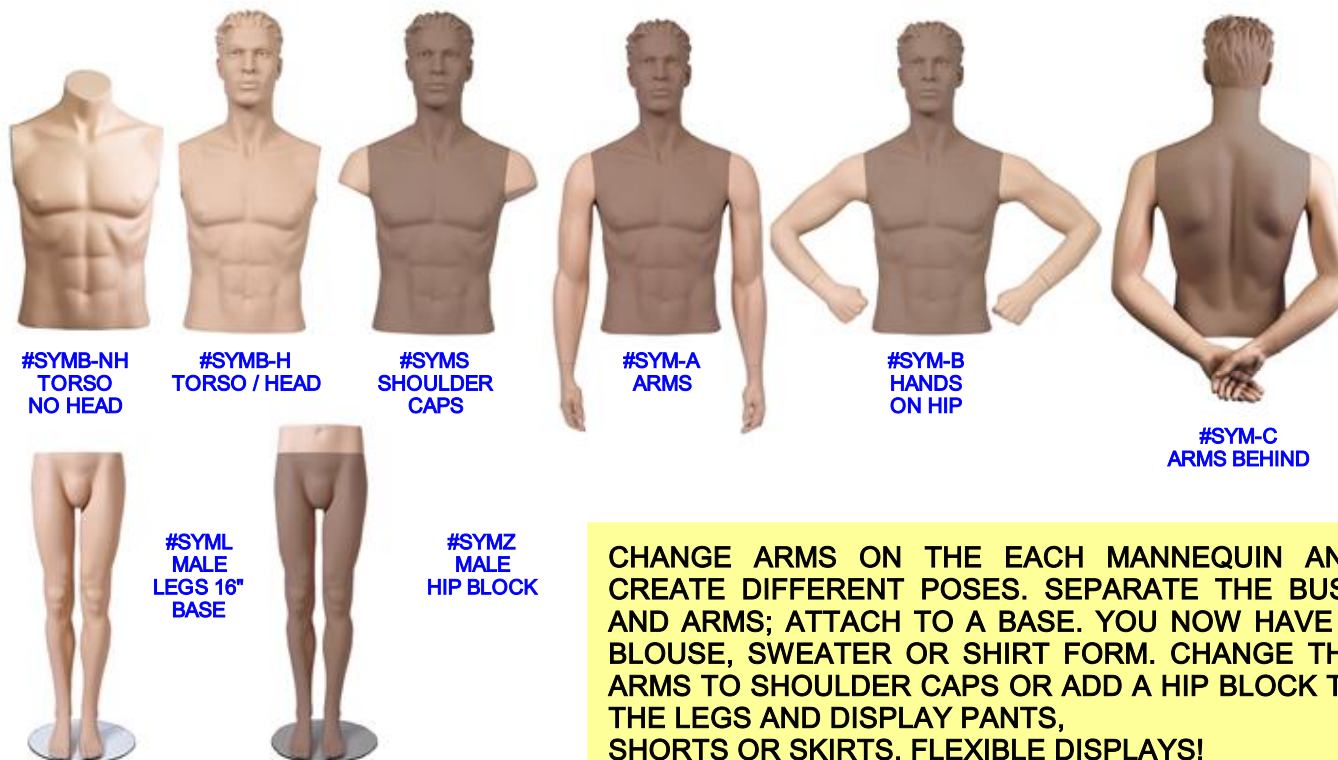

#SYMB-NH  
TORSO  
NO HEAD

#SYMB-H  
TORSO / HEAD

#SYMS  
SHOULDER  
CAPS

#SYM-A  
ARMS

#SYM-B  
HANDS  
ON HIP

#SYM-C  
ARMS BEHIND

#SYML  
MALE  
LEGS 16"  
BASE

#SYMZ  
MALE  
HIP BLOCK

CHANGE ARMS ON THE EACH MANNEQUIN AND CREATE DIFFERENT POSES. SEPARATE THE BUST AND ARMS; ATTACH TO A BASE. YOU NOW HAVE A BLOUSE, SWEATER OR SHIRT FORM. CHANGE THE ARMS TO SHOULDER CAPS OR ADD A HIP BLOCK TO THE LEGS AND DISPLAY PANTS, SHORTS OR SKIRTS. FLEXIBLE DISPLAYS!

nuease@aol.com | TEL: 201.723.8941 | FAX: 1-201-837-9427

NAVIGATE

- [NEXT >](#)
- [< BACK](#)
- [INDEX](#)

ORDERING 1,2,3

- [HOW TO ORDER](#)
- [PRICE LIST](#)
- [ORDER FORM](#)
- [E-MAIL ORDER](#)

COMPLETE INDEX

- [CATALOG INDEX](#)
- [DOWNLOAD PDF CATALOG](#)
- [CONTACT US](#)

SEND ORDER FORM AS EMAIL ATTACHMENT

WARDROBE SUPPLY



WARDROBE SUPPLY



#SYTF

#SYFS

#SYF-A

#SYF-B

#SYF-C

3/4 TORSO FORMS AVAILABLE WITH WIRE HANGING LOOP



#SYTM

#SYMS

#SYM-A

#SYM-B

#SYM-C

3/4 TORSO FORMS WORK WITH BASES SHOWN BELOW LEFT



RELATED ITEMS



HANGING BODYFORMS



JERSEY FORMS

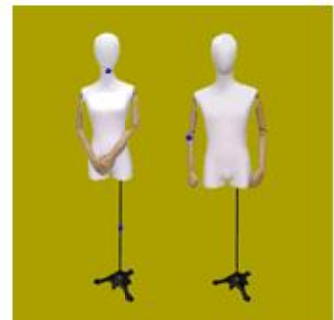

FLEXIBLE JERSEY FORMS



SEXY MANNEQUINS



NEW ITEMS



WARDROBE SUPPLY

BASES / COUNTER FORMS

BLACK - WHITE

FORM BASES

COUNTER FORMS



#MR1

#MR2/SC

#MR1/SC



#XS1478W

#XS198B

#MR1: 25"H - NATURAL / CHROME UPRIGHT [7/8" UPRIGHT FITS TORSO FORMS]  
 OVAL WOOD BASES: NATURAL LACQUER  
 SATIN CHROME BASES:  
 #MR1/SC: OFFSET BASE - 5/8" & 7/8" UPRIGHTS  
 #MR2/SC: ROUND BASE - 5/8" & 7/8" UPRIGHTS

#XS1478B/W: FEMALE - BLACK / WHITE  
 #XS198B/W: MALE - BLACK / WHITE  
 OPEN BACK PLASTIC HANGER FORMS WITH CHROME UPRIGHT AND CRYSTAL BASE.

nuease@aol.com | TEL: 201.723.8941 | FAX: 1-201-837-9427

NAVIGATE



ORDERING 1,2,3



COMPLETE INDEX



SEND ORDER FORM AS EMAIL ATTACHMENT  
 WF WII | PRINT & DEL FTF IMMEDIATELY

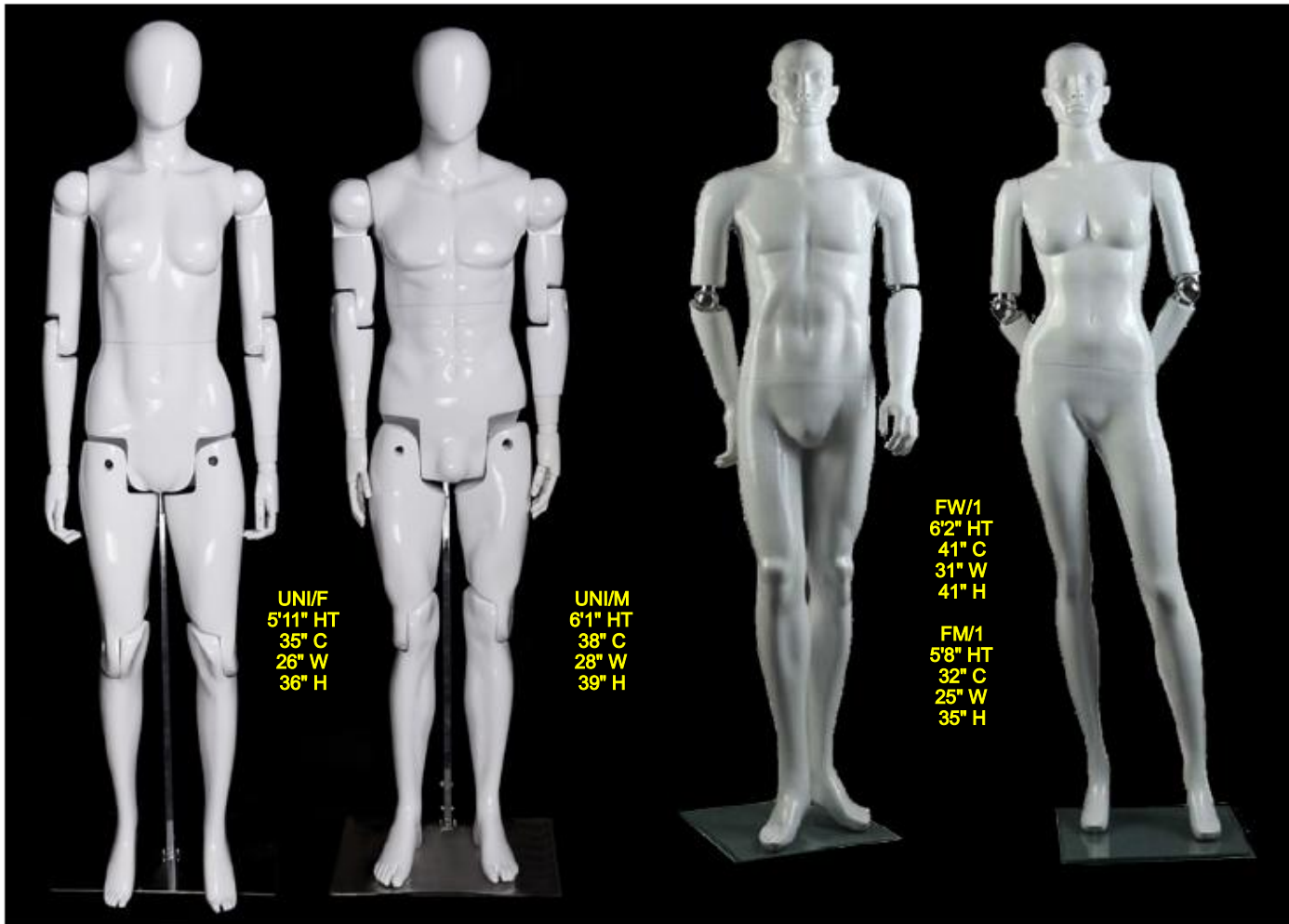

JERSEY FORMS



FLEXIBLE JERSEY FORMS



SEXY MANNEQUINS

COSTUMER FORMS

BLACK

WHITE JERSEY COVERED BENDABLE FOAM



#FLC3 = 3 - 4 YEAR  
#FLC5 = 6 - 7 YEAR

#FLC7 = 7 - 8 YEAR  
#FLC9 = 9 - 10 YEAR

MATTE BLACK

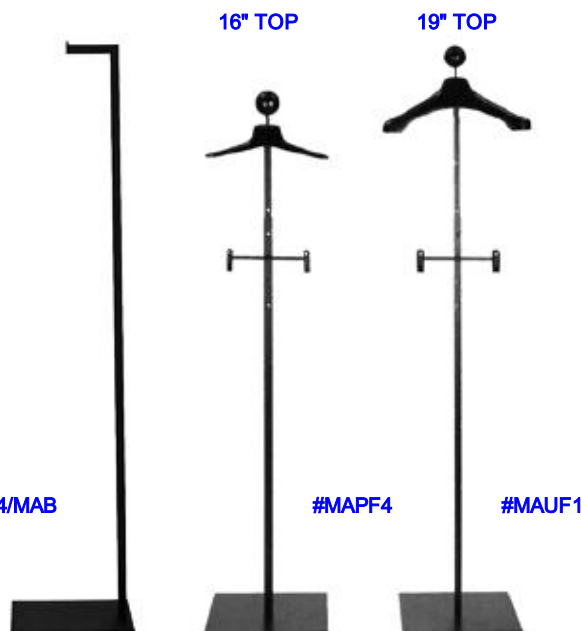

#VM504/MAB

#MAPF4

#MAUF1

#VM504/MAB: 51-78"H  
ADJ. COSTUMER FOR  
HANGING FORMS.

#MAPF4/MAB: JUNIOR - LADIES  
HT: 53-72", WIDTH: 15½"  
#MAUF1/MAB: UNISEX - MEN  
BASE: 15X15", H: 53-72", W: 19"

NEW ITEMS PAGE

NEW ITEMS

CLEARANCE PAGE

CLOSE-OUT ITEMS

WARDROBE SUPPLY



WARDROBE SUPPLY

nuease@aol.com | TEL: 201.723.8941 | FAX: 1-201-837-9427

NAVIGATE

NEXT>

<BACK

INDEX

ORDERING 1,2,3

HOW TO ORDER

PRICE LIST

ORDER FORM

E-MAIL ORDER

COMPLETE INDEX

CATALOG INDEX

DOWNLOAD PDF CATALOG

CONTACT US

SEND ORDER FORM AS EMAIL ATTACHMENT  
WF WII | PRINT & DFI FTF IMMEDIATFI Y

JERSEY COVERED FORMS ARE MADE WITH HIGH QUALITY FABRIC. FORMS ARE COVERED WITH A LAYER FOAM RUBBER FOR EASY PINNING. EACH FORM IS PRE-SELECTED WITH NECK BLOCK AND BLACK METAL BASE. FORMS ARE HEIGHT ADJUSTABLE.

BODY FORMS

3/4 TORSO FORMS



#BFF/C-M: FEMALE NATURAL -- #BFF/B-M: BLACK [SIZE: 6]  
#BFM/C-M: MALE NATURAL -- #BFM/B-M: BLACK [SIZE: 40]  
3/4 BODY FORMS MOUNTED ON SATIN CHROME BASES WITH SATIN CHROME NECK BLOCKS. SOLD AS COMPLETE UNITS.

#BFF-3/4C-M: FEMALE TORSO FORM [SIZE: 6]  
#BFM-3/4C-M: MALE TORSO FORM [SIZE: 40]  
3/4 TORSO BODY FORMS WITH BLACK NECK BLOCK AND BLACK METAL BASE INCLUDED. CAMEO WHITE ONLY.



BENDABLE MANNEQUINS



FLEXIBLE JERSEY FORMS



SEXY MANNEQUINS

DRESSMAKER FORM

CAMEO



A GENUINE DRESSMAKERS FORM IN TWO SIZES. COLLAPSIBLE SHOULDERS FOR EASE OF DRESSING FORM. A NATURAL FINISH. INCLUDES DRESSMAKER ROLLING BASES WITH PEDAL.

#DMB/1: CHROME ROLLING BASE DRESSMAKER'S BASE WITH 7/8" UPRIGHT CAN BE USED ON #BFF & BFM FORMS. FORMS ADJUSTABLE ON DRESSMAKER BASES: 48" TO 64". CHROME FINISH

#DMB/SWAP: ROLLING BASE SWAP CAN BE SWAPPED FOR SQUARE SATIN CHROME BASE THAT COMES WITH FORM. JUST PAY SMALL DIFFERENCE IN COST.

#DMF-6: SIZE 6  
#DMF-8: SIZE 8  
A GENUINE DRESSMAKERS FORM IN TWO SIZES. COLLAPSIBLE SHOULDERS FOR EASE OF DRESSING FORM. A NATURAL FINISH. INCLUDES DRESSMAKER ROLLING BASE WITH PEDAL. THE REAL DEAL!



NEW ITEMS PAGE

NEW ITEMS

CLEARANCE PAGE

CLOSE-OUT ITEMS

WARDROBE SUPPLY



WARDROBE SUPPLY

nuease@aol.com | TEL: 201.723.8941 | FAX: 1-201-837-9427

NAVIGATE

- NEXT >
- < BACK
- INDEX

ORDERING 1,2,3

- HOW TO ORDER
- PRICE LIST
- ORDER FORM
- E-MAIL ORDER

COMPLETE INDEX

- CATALOG INDEX
- DOWNLOAD PDF CATALOG
- CONTACT US

SEND ORDER FORM AS EMAIL ATTACHMENT  
WE WILL PRINT & DELIVER IMMEDIATELY

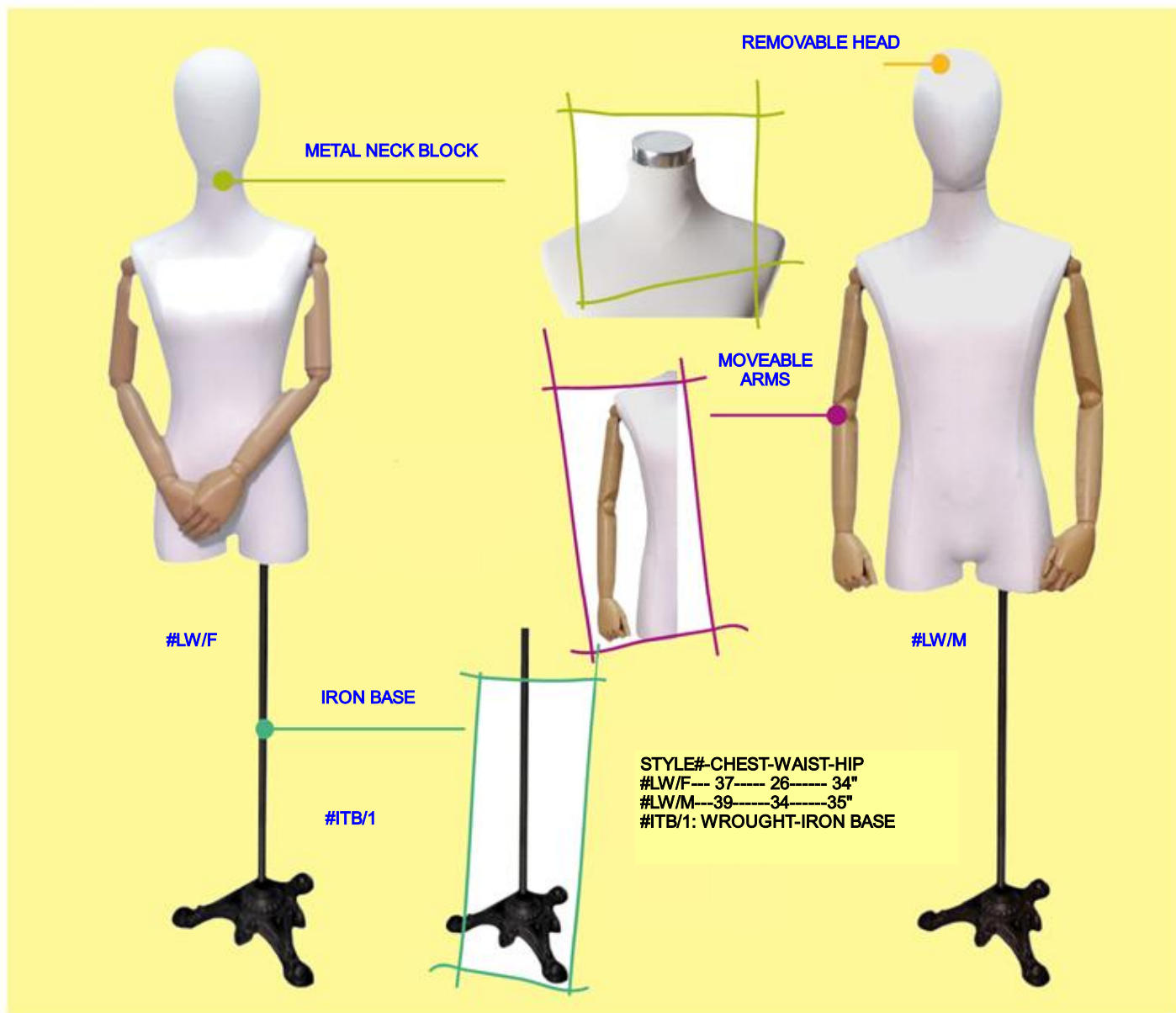

BENDABLE MANNEQUINS



JERSEY FORMS



SEXY MANNEQUINS

COUNTERTOP FORMS

CREAM / WHITE



BODY FORMS: CREAM  
 BFHF/C-M 37 X 26W"  
 BFHM/C-M 39 X 34W"  
 SATIN CHROME BASE  
 NECK BLOCK INCLUDED

COUNTER FORMS:  
 GLOSS WHITE  
 HM/FHG 33 X 24W"  
 HM/MHG 34 X 29W"  
 SATIN CHROME  
 BASE INCLUDED

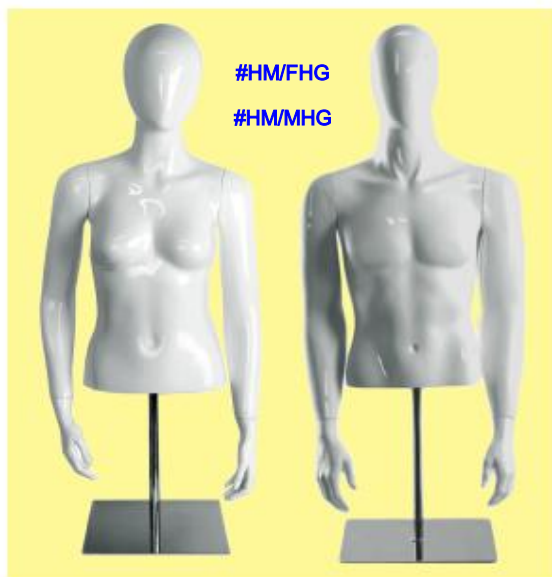

NEW ITEMS PAGE

NEW ITEMS

CLEARANCE PAGE

CLOSE-OUT ITEMS

WARDROBE SUPPLY



WARDROBE SUPPLY

nuease@aol.com | TEL: 201.723.8941 | FAX: 1-201-837-9427

NAVIGATE

- [NEXT >](#)
- [< BACK](#)
- [INDEX](#)

ORDERING 1,2,3

- [HOW TO ORDER](#)
- [PRICE LIST](#)
- [ORDER FORM](#)
- [E-MAIL ORDER](#)

COMPLETE INDEX

- [CATALOG INDEX](#)
- [DOWNLOAD PDF CATALOG](#)
- [CONTACT US](#)

SEND ORDER FORM AS EMAIL ATTACHMENT  
 WE WILL PRINT & DELETE IMMEDIATELY

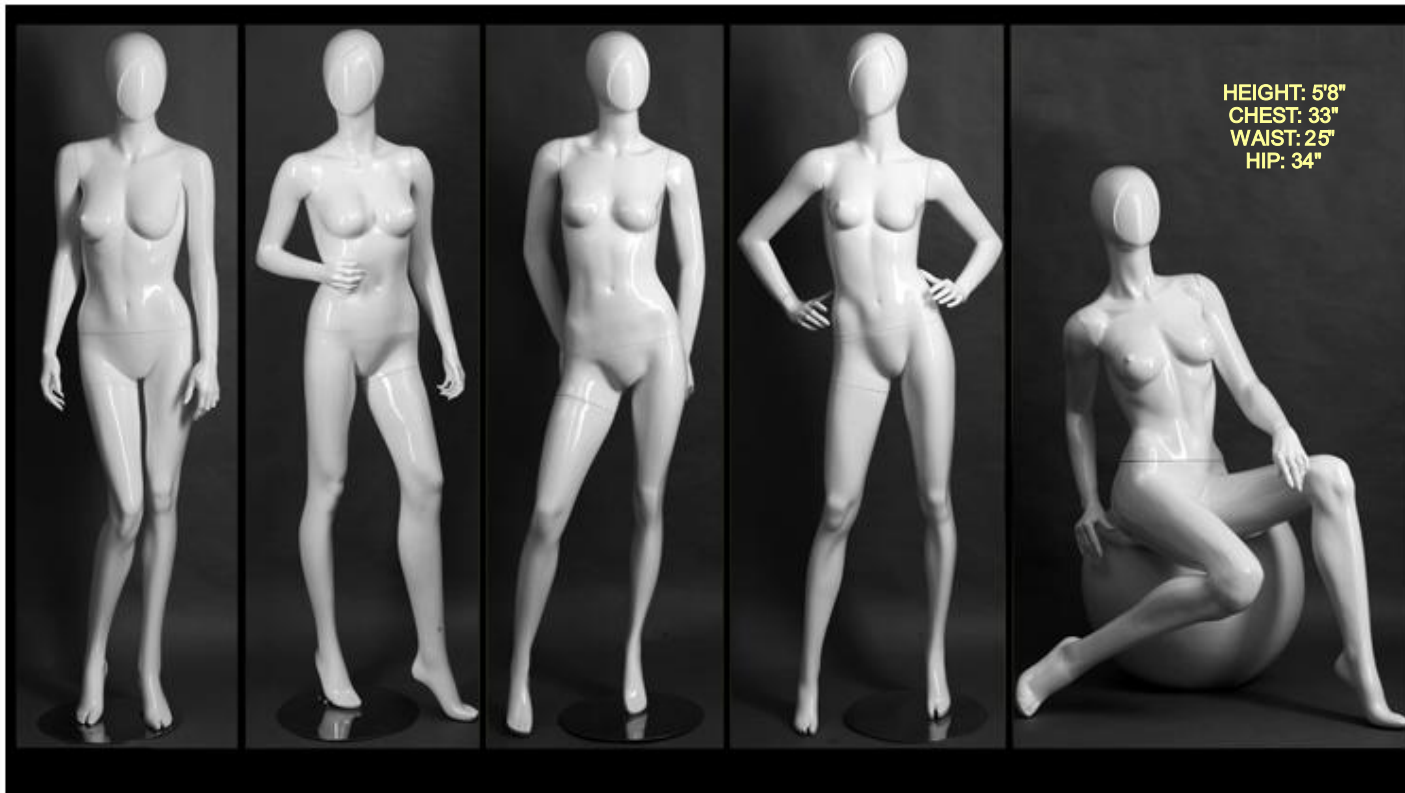

HEIGHT: 5'8"  
CHEST: 33"  
WAIST: 25"  
HIP: 34"

#SAMANTHA/1

#SAMANTHA/2

#SAMANTHA/3

#SAMANTHA/4

#SAMANTHA/5

**SAME DAY DELIVERY!**



NYC, BROOKLYN, NJ

SAME DAY DELIVERY!

**JUST FOR FUN**

JUST FOR FUN!

**FLICKER FUNNIES**

JUST FOR FUN!

**NEW ITEMS PAGE**

NEW ITEMS

**CLEARANCE PAGE**

CLOSE-OUT ITEMS

**WARDROBE SUPPLY**



WARDROBE SUPPLY

PLUS SIZE MANNEQUINS

MATTE WHITE / GLOSSY WHITE

THE "JANET SERIES" FINALLY PRESENTS MANNEQUINS IN NEEDED PLUS SIZES IN A DIVERSE VARIETY OF POSES TO ALLOW A FASHIONABLE PRESENTATION OF LARGER SIZES IN THE MODERN RETAIL ENVIRONMENT. ROUND CHROME BASES ARE INCLUDED FOR A CLEAN LOOK AND THE FORMS ARE FEATURED IN BOTH MATTE AND GLOSSY FINISHES. JANET IS NOW!

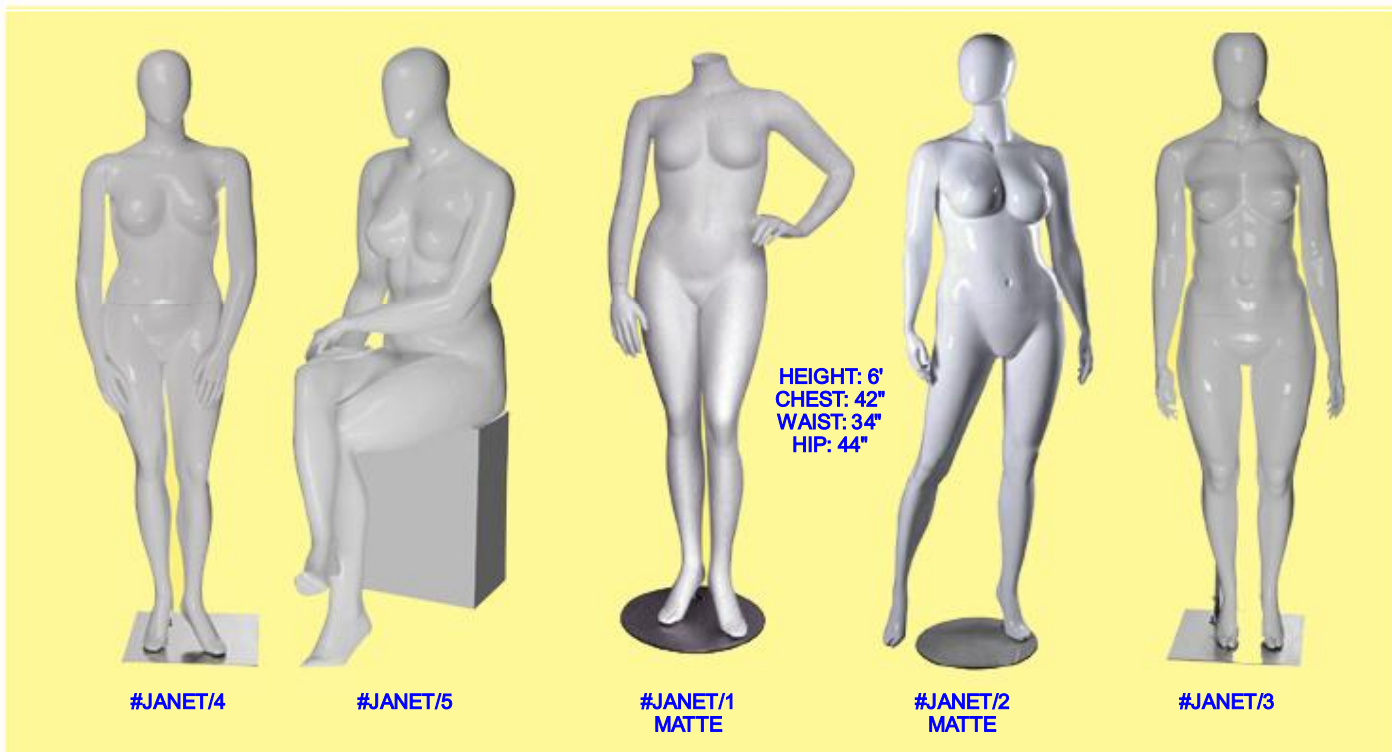

HEIGHT: 6'  
CHEST: 42"  
WAIST: 34"  
HIP: 44"

#JANET/4

#JANET/5

#JANET/1  
MATTE

#JANET/2  
MATTE

#JANET/3

nuease@aol.com | TEL: 201.723.8941 | FAX: 1-201-837-9427

NAVIGATE

**NEXT>**

**<BACK**

**INDEX**

ORDERING 1,2,3

**HOW TO ORDER**

**PRICE LIST**

**ORDER FORM**

**E-MAIL ORDER**

COMPLETE INDEX

**CATALOG INDEX**

**DOWNLOAD PDF CATALOG**

**CONTACT US**

SEND ORDER FORM AS EMAIL ATTACHMENT  
WE WILL PRINT & DELETE IMMEDIATELY

GLOSSY BLACK ABSTRACT MANNEQUINS



#MIKE/2  
#MIKE/3  
#MICHELLE/3  
#MICHELLE/4

HEIGHT	CHEST	WAIST	HIP / >>>> BASE
6'2"	39"	31"	38" / >>>> CHROME-ROUND
6'2"	39"	31"	38" / >>>> CHROME-ROUND
5'9"	33"	24"	34" / >>>> CHROME-ROUND
5'9"	34"	25"	36" / >>>> CHROME-ROUND

METALLIC GREY ATHLETIC MANNEQUINS



#BEN/1  
#BEN/2  
#JACKIE/2  
#JACKIE/3

HEIGHT	CHEST	WAIST	HIP / >>>> BASE
5'10"	44"	35"	42" / >>>> CHROME-SQUARE
5'8"	36"	28"	36" / >>>> CHROME-SQUARE
5'4"	34"	27"	35" / >>>> CHROME-SQUARE
5'3"	36"	27"	34" / >>>> CHROME-SQUARE

RELATED ITEMS

CLEARANCE PAGE

CLOSE-OUT ITEMS

JUST FOR FUN

JUST FOR FUN!

FLICKER FUNNIES

JUST FOR FUN!

**DID YOU KNOW?**  
TABCO DESIGNED MANY ITEMS USED BY THE GARMENT IND. TODAY!  
TRAVEL AUTO BAG SINCE 1933!

DID YOU KNOW?

SAME DAY DELIVERY!



NYC, BROOKLYN, NJ

SAME DAY DELIVERY!

**WARDROBE SUPPLY**  
EVERYTHING FOR WARDROBE  
ON LOCATION  
IN STUDIO  
NYC NJ DAILY VAN MANHATTAN SINCE 1933

WARDROBE SUPPLY

nuease@aol.com | TEL: 201.723.8941 | FAX: 1-201-837-9427

NAVIGATE

NEXT>

<BACK

INDEX

ORDERING 1,2,3

HOW TO ORDER

PRICE LIST

ORDER FORM

E-MAIL ORDER

COMPLETE INDEX

CATALOG INDEX

DOWNLOAD PDF CATALOG

CONTACT US

SEND ORDER FORM AS EMAIL ATTACHMENT  
WE WILL PRINT & DELETE IMMEDIATELY



CONTOUR JACKET HANGER



SHAPELY MANNEQUINS



RELATED ITEMS



98% OF ITEMS STOCKED!



JUST FOR FUN!



JUST FOR FUN!



DID YOU KNOW?

WISHBONE SUIT HANGER



WISHBONE SUIT HANGER



NATURAL WOOD BASE

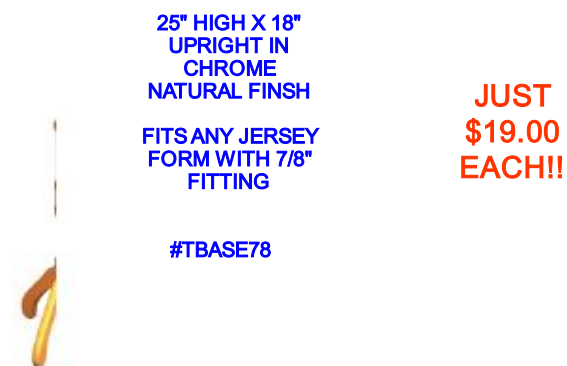

WALNUT SKIRT HANGER

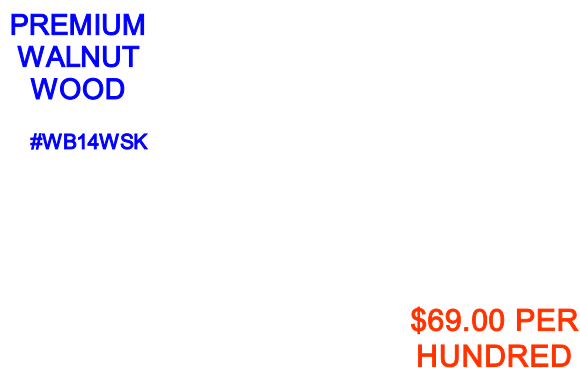

SAME DAY DELIVERY!



WARDROBE SUPPLY

nuease@aol.com | TEL: 201.723.8941 | FAX: 1-201-837-9427

NAVIG

NE

<BA

IND

COMPLETE INDEX

SEND ORDER FORM AS EMAIL ATTACHMENT  
WE WILL PRINT & DELIVER IMMEDIATELY

SOMETHING DIFFERENT!



CANVAS GRIP-TITE BAG



OPAQUE ZIPPERED BAG



NON-WOVEN BAGS



CLEAR GOWN BAGS

CLEARANCE PAGE

CLOSE-OUT ITEMS



BRIDAL COVERS



GUSSETED BRIDAL BAG



CLEAR DRAWSTRING BAG



NEW STEAMER!

JUST FOR FUN

JUST FOR FUN!



ROLLING HARD CASE



PROP CASES



FOLDING ROLLING RACK



"BIG WHEELER"

FLICKER FUNNIES

JUST FOR FUN!



CHROME WIRE HANGERS



PLASTIC HANGER



CONTOUR JACKET



WISHBONE WOOD

**DID YOU KNOW?**  
 TABCO DESIGNED MANY ITEMS USED BY THE GARMENT IND. TODAY!  
  
 TRAVEL AUTO BAG SINCE 1933!

DID YOU KNOW?



VELVET SLIM-LINE



ZEE RACKS / COVERS



CLASSIC PIPE RACKS



COSTUMERS

**SAME DAY DELIVERY!**  
  
 NYC, BROOKLYN, NJ  
 SAME DAY DELIVERY!

98% IN STOCK



98% OF ITEMS STOCKED!

nuease@aol.com | TEL: 201.723.8941 | FAX: 1-201-837-9427

NAVIGATE

NEXT>

<BACK

INDEX

ORDERING 1,2,3

HOW TO ORDER

PRICE LIST

ORDER FORM

E-MAIL ORDER

COMPLETE INDEX

CATALOG INDEX

DOWNLOAD PDF CATALOG

CONTACT US

SEND ORDER FORM AS EMAIL ATTACHMENT  
 WF WII I PRINT & DFI FTF IMMEDIATFI Y

**MEDIUM-RARE**[CLICK ABOVE FOR EXCERPT](#)

"Medium-Rare" recounts the bizarre story of an evening at the Bijou theater. It's not about a movie or a musical, but a psychic!

Dr. Peter Von Pepperhoff has journeyed from Austrian academia to late night TV and dazzled all. The bearded wonder confounded TV audiences with an amazing ability to summon and speak for the dead. There's a hysterical anticipation of his new venue, the live display of his mastery of the netherworld. On this night, the dead will be conjured for the placation of their offspring, spirits from the unknown will be beckoned to assuage the mournful . . . and Dr. Pepper is going to do it . . . really!

They are coming! Oddly, no one will be more surprised than the Doctor!

MEDIUM-RARE, a novel by ROSS COOPER / Reg. Copyright - Reg. WGAw

[CLICK BELOW FOR AUDIO](#)**SHORT STORY**

THE PLUNGE

or

"My initiation into the mysterious society of the afternoon martini and finger sandwich."

**SHORT STORY**

LA PETITE MORT

or

"A bed awaited us to endure the night, when the little death comes for our consciousness, leaving only the security of our embrace."

**SHORT STORY**

THE LOVE NEST

or

"Words were not necessary, because we were one."

[LISTEN TO NARRATIONS BY BBC GREAT, SIR NIGEL NEVERDONE!](#)  
[CLICK "SHORT STORY" ABOVE.](#)

[CLICK BELOW FOR STORY](#)**UNREAL, BUT TRUE!**

"The 'Laker Girl' finds peace at Travel Auto Bag?"

**UNREAL, BUT TRUE!**

"Why is Ramses II looking at me . . . at my desk?"

**QUOTATIONS**

"Life is just a brief spin around the rim ... before being lost forever down eternity's glug-hole!"  
--ROSS COOPER [from THE CAROUSEL]

"There is nothing one wants that is worth working hard for. What is truly desired never seems like hard work."  
--ROSS COOPER

"It's really pathetic how these young fella's navigate the uncertain waters of stocks and bonds, knowing just how expendable they are. Any market fluctuation can flush them out to sea ... just like so much plankton for the whales to gulp, tons at a time."  
--ROSS COOPER [from THE CAROUSEL]

In Italy, for 30 years under the Borgias, they had warfare, terror, murder and bloodshed, but they produced Michelangelo, Leonardo da Vinci and the Renaissance. In Switzerland they had brotherly love, they had 500 years of democracy and peace - and what did that produce? The cuckoo clock.  
--ORSON WELLES [ad-libbed in "THE THIRD MAN"]

"One day, you will reach into that top hat and find the rabbit is missing!"  
--ROSS COOPER [from THE CAROUSEL]

"Trust everybody, but cut the cards."  
--FINLEY PETER DUNNE

**FLICKER  
FUNNIES**

JUST FOR FUN!

**NEW ITEMS  
PAGE**

NEW ITEMS

**CLEARANCE  
PAGE**

CLOSE-OUT ITEMS

**WARDROBE SUPPLY**

WARDROBE SUPPLY

[nuease@aol.com](mailto:nuease@aol.com) | TEL: 201.723.8941 | FAX: 1-201-837-9427

## NAVIGATE

**NEXT>****<BACK****INDEX**

## ORDERING 1,2,3

**HOW TO ORDER****PRICE LIST****ORDER FORM****E-MAIL ORDER**

## COMPLETE INDEX

**CATALOG INDEX****DOWNLOAD PDF CATALOG****CONTACT US**

[SEND ORDER FORM AS EMAIL ATTACHMENT](#)  
[WE WILL PRINT & DELETE IMMEDIATELY](#)



THE BABYSITTER REBELS



THE "GARMENT CENTER": circa 1890



LOSING YOUR HEAD FOR THE WRONG



SHE HAS A "HUNCH" ABOUT HER



FIFTH AVENUE: circa 1930



HE JUST DIDN'T KNOW



COFFEE, COFFEE, COFFEE...



"THE BOOKKEEPER"



LOVE IN THE RATHSKELLER



nuease@aol.com | TEL: 201.723.8941 | FAX: 1-201-837-9427

NAVIGATE

[<BACK](#)

[INDEX](#)

[HOME](#)

ORDERING 1,2,3

[HOW TO ORDER](#)

[PRICE LIST](#)

[ORDER FORM](#)

[E-MAIL ORDER](#)

COMPLETE INDEX

[CATALOG INDEX](#)

[DOWNLOAD PDF CATALOG](#)

[CONTACT US](#)

SEND ORDER FORM AS EMAIL ATTACHMENT  
WE WILL PRINT & DELETE IMMEDIATELY